

Particle Detectors

(Horst Wahl, Quarknet lecture, June 2001)

Outline:

- particle physics experiments - introduction
- interactions of particles with matter
- detectors
- triggers
- D0 detector
- CMS detector

- Webpages of interest
 - <http://www.fnal.gov> (Fermilab homepage)
 - <http://www.hep.fsu.edu/~wahl/Quarknet> (has links to many particle physics sites)
 - <http://www.fnal.gov/pub/tour.html> (Fermilab particle physics tour)
 - <http://ParticleAdventure.org/> (Lawrence Berkeley Lab.)
 - <http://www.cern.ch> (CERN -- European Laboratory for Particle Physics)

Particle physics experiments

- Particle physics experiments:
 - collide particles to
 - ◆ produce new particles
 - ◆ reveal their internal structure and laws of their interactions by observing regularities, measuring cross sections,...
 - colliding particles need to have high energy
 - ◆ to make objects of large mass
 - ◆ to resolve structure at small distances
 - to study structure of small objects:
 - ◆ need probe with short wavelength: use particles with high momentum to get short wavelength
 - ◆ remember de Broglie wavelength of a particle
 $\lambda = h/p$
 - in particle physics, mass-energy equivalence plays an important role; in collisions, *kinetic energy converted into mass energy*:
 - ◆ relation between kinetic energy K, total energy E and momentum p :
$$E = K + mc^2 = \sqrt{(pc)^2 + (mc^2)^2}$$

How to do a particle physics experiment

- Outline of experiment:
 - get particles (e.g. protons, antiprotons,...)
 - accelerate them
 - throw them against each other
 - observe and record what happens
 - analyse and interpret the data
- ingredients needed:
 - particle source
 - accelerator and aiming device
 - detector
 - trigger (decide what to record)
 - recording device
 - many people to:
 - ◆ design, build, test, operate accelerator
 - ◆ design, build, test, calibrate, operate, and understand detector
 - ◆ analyze data
 - lots of money to pay for all of this

About Units

- Energy - *electron-volt*
 - 1 electron-volt = kinetic energy of an electron when moving through potential difference of 1 Volt;
 - ◆ $1 \text{ eV} = 1.6 \times 10^{-19} \text{ Joules} = 2.1 \times 10^{-6} \text{ W}\cdot\text{s}$
 - ◆ $1 \text{ kW}\cdot\text{hr} = 3.6 \times 10^6 \text{ Joules} = 2.25 \times 10^{25} \text{ eV}$
- mass - eV/c^2
 - ◆ $1 \text{ eV}/c^2 = 1.78 \times 10^{-36} \text{ kg}$
 - ◆ electron mass = $0.511 \text{ MeV}/c^2$
 - ◆ proton mass = $938 \text{ MeV}/c^2$
 - ◆ professor's mass (80 kg) $\approx 4.5 \times 10^{37} \text{ eV}/c^2$
- momentum - eV/c :
 - ◆ $1 \text{ eV}/c = 5.3 \times 10^{-28} \text{ kg m/s}$
 - ◆ momentum of baseball at 80 mi/hr
 $\approx 5.29 \text{ kgm/s} \approx 9.9 \times 10^{27} \text{ eV}/c$

WHY CAN'T WE SEE ATOMS?

- “seeing an object”
 - = detecting light that has been reflected off the object's surface
- light = electromagnetic wave;
- “visible light”= those electromagnetic waves that our eyes can detect
- “wavelength” of e.m. wave (distance between two successive crests) determines “color” of light
- wave hardly influenced by object if size of object is much smaller than wavelength
- wavelength of visible light:
 - between 4×10^{-7} m (violet) and 7×10^{-7} m (red);
- diameter of atoms: 10^{-10} m
- generalize meaning of seeing:
 - seeing is to detect effect due to the presence of an object
- quantum theory \Rightarrow “particle waves”,
 - with wavelength $\propto 1/(m v)$
- use accelerated (charged) particles as probe, can “tune” wavelength by choosing mass m and changing velocity v
- this method is used in electron microscope, as well as in “scattering experiments” in nuclear and particle physics

Detectors

● Detectors

- use characteristic effects from interaction of particle with matter to detect, identify and/or measure properties of particle; has "transducer" to translate direct effect into observable/recordable (e.g. electrical) signal
- example: *our eye is a photon detector*; (photons = light "quanta" = packets of light)
- "*seeing*" is performing a *photon scattering experiment*:
 - ◆ light source provides photons
 - ◆ photons hit object of our interest -- some absorbed, some scattered, reflected
 - ◆ some of scattered/reflected photons make it into eye; focused onto retina;
 - ◆ photons detected by sensors in retina (photoreceptors -- rods and cones)
 - ◆ transduced into electrical signal (nerve pulse)
 - ◆ amplified when needed
 - ◆ transmitted to brain for processing and interpretation

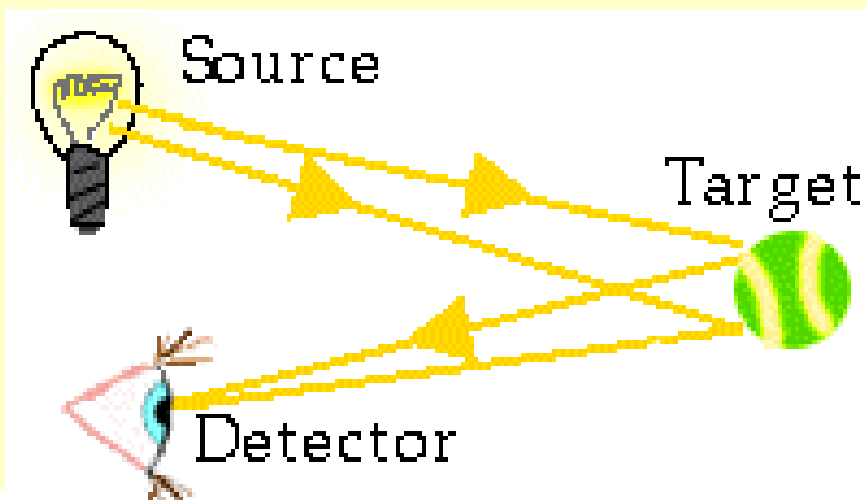

Particle interactions with matter

- electromagnetic interactions:
 - ◆ excitation
 - ◆ ionization
 - ◆ Cherenkov radiation
 - ◆ transmission radiation
 - ◆ bremsstrahlung
 - ◆ photoelectric effect
 - ◆ Compton scattering
 - ◆ pair production
- strong interactions:
 - ◆ secondary hadron production,
 - ◆ hadronic showers
- detectors usually have some amplification mechanism

Interaction of particles with matter

- when passing through matter,
 - particles interact with the electrons and/or nuclei of the medium;
 - this interaction can be *weak, electromagnetic* or *strong interaction*, depending on the kind of particle; its effects can be used to detect the particles;
- possible interactions and effects in passage of particles through matter:
 - **excitation** of atoms or molecules (e.m. int.):
 - ◆ charged particles can excite an atom or molecule (i.e. lift electron to higher energy state);
 - ◆ subsequent de-excitation leads to emission of photons;
 - **ionization** (e.m. int.)
 - ◆ electrons liberated from atom or molecule, can be collected, and charge is detected
 - **Cherenkov radiation** (e.m. int.):
 - ◆ if particle's speed is higher than speed of light in the medium, e.m. radiation is emitted -- "Cherenkov light" or Cherenkov radiation, which can be detected;
 - ◆ amount of light and angle of emission depend on particle velocity;

Interaction of particles with matter, cont'd

- **transition radiation** (e.m. int.):
 - ◆ when a charged particle crosses the boundary between two media with different speeds of light (different "refractive index"), e.m. radiation is emitted -- "transition radiation"
 - ◆ amount of radiation grows with (energy/mass);
- **bremsstrahlung** (= braking radiation) (e.m. int.):
 - ◆ when charged particle's velocity changes, e.m. radiation is emitted;
 - ◆ due to interaction with nuclei, particles deflected and slowed down emit bremsstrahlung;
 - ◆ effect stronger, the bigger (energy/mass) \Rightarrow electrons with high energy most strongly affected;
- **pair production** (e.m. int.):
 - ◆ by interaction with e.m. field of nucleus, photons can convert into electron-positron pairs
- **electromagnetic shower** (e.m. int.):
 - ◆ high energy electrons and photons can cause "*electromagnetic shower*" by successive bremsstrahlung and pair production
- **hadron production** (strong int.):
 - ◆ strongly interacting particles can produce new particles by strong interaction, which in turn can produce particles,... "*hadronic shower*"

Scintillation counter

- Scintillation counter:
 - energy liberated in de-excitation and capture of ionization electrons emitted as light - "scintillation light"
 - light channeled to photomultiplier in light guide (e.g. piece of lucite or optical fibers);
 - scintillating materials: certain crystals (e.g. NaI), transparent plastics with doping (fluors and wavelength shifters)

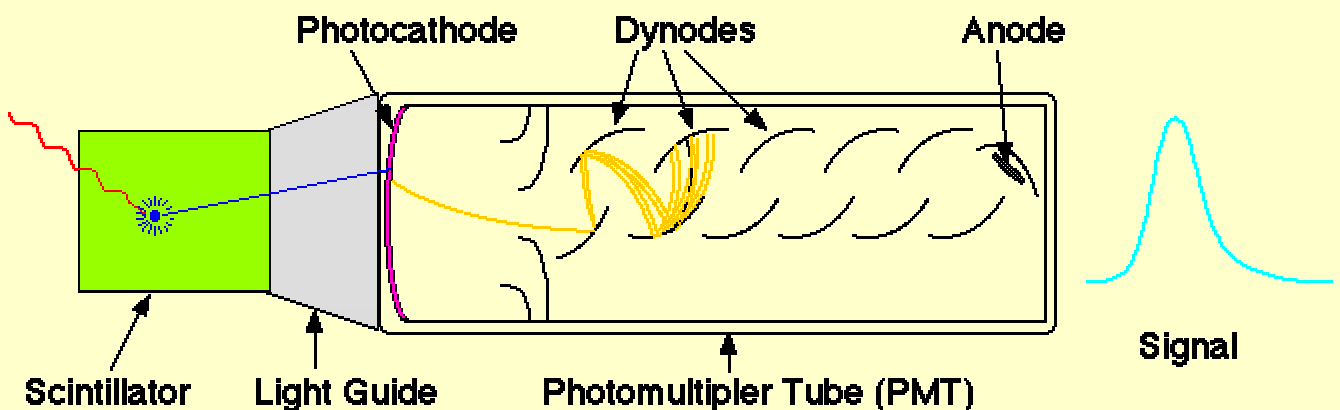
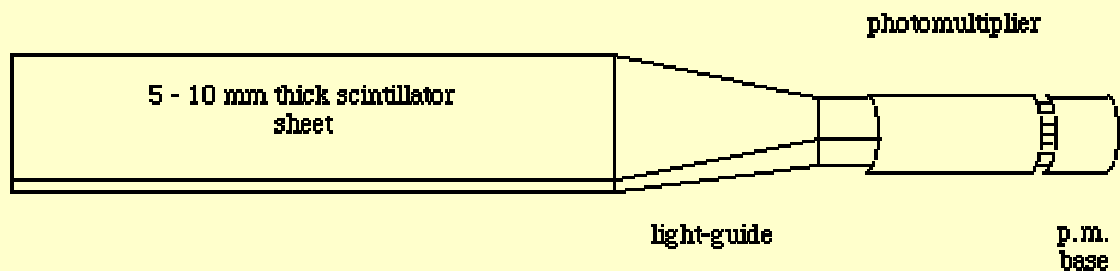

Photomultiplier

- photomultiplier tubes convert small light signal (even single photon) into detectable charge (current pulse)
- photons liberate electrons from photocathode,
- electrons “multiplied” in several (6 to 14) stages by ionization and acceleration in high electric field between “dynodes”, with gain $\approx 10^4$ to 10^{10}
- photocathode and dynodes made from material with low ionization energy;
- photocathodes: thin layer of semiconductor made e.g. from Sb (antimony) plus one or more alkali metals, deposited on glass or quartz;
- dynodes: alkali or alkaline earth metal oxide deposited on metal, e.g. BeO on Cu (gives high secondary emission);

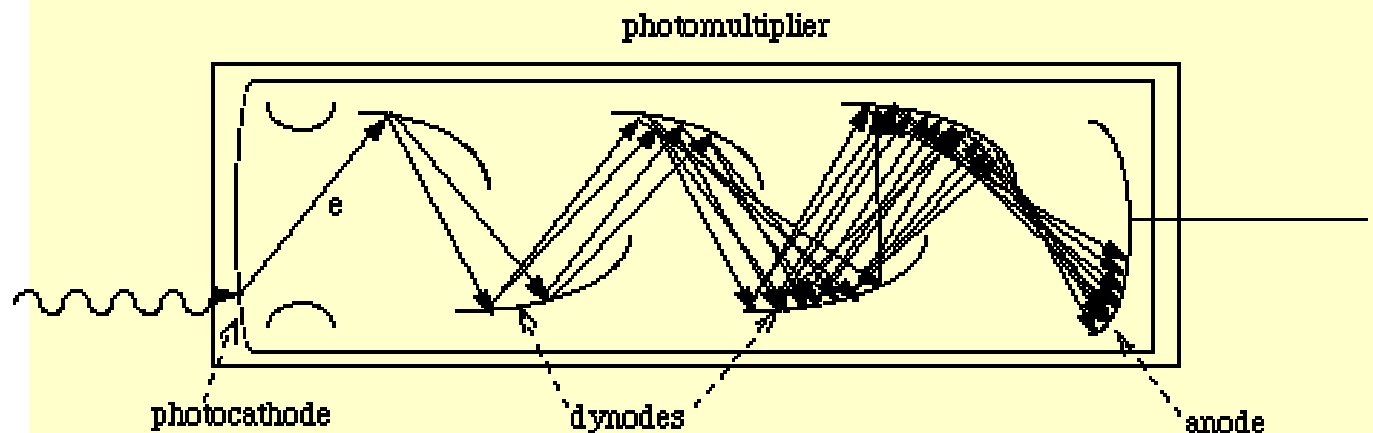

Spark chamber

- gas volume with metal plates (electrodes); filled with gas (noble gas, e.g. argon)
- charged particle in gas \Rightarrow ionization \Rightarrow electrons liberated; \Rightarrow string of electron - ion pairs along particle path
- passage of particle through "trigger counters" (scintillation counters) triggers HV
- HV between electrodes \Rightarrow strong electric field;
- electrons accelerated in electric field \Rightarrow can liberate other electrons by ionization which in turn are accelerated and ionize \Rightarrow "avalanche of electrons", eventually formation of plasma between electrodes along particle path;
- gas conductive along particle path \Rightarrow electric breakdown \Rightarrow discharge \Rightarrow spark
- HV turned off to avoid discharge in whole gas volume

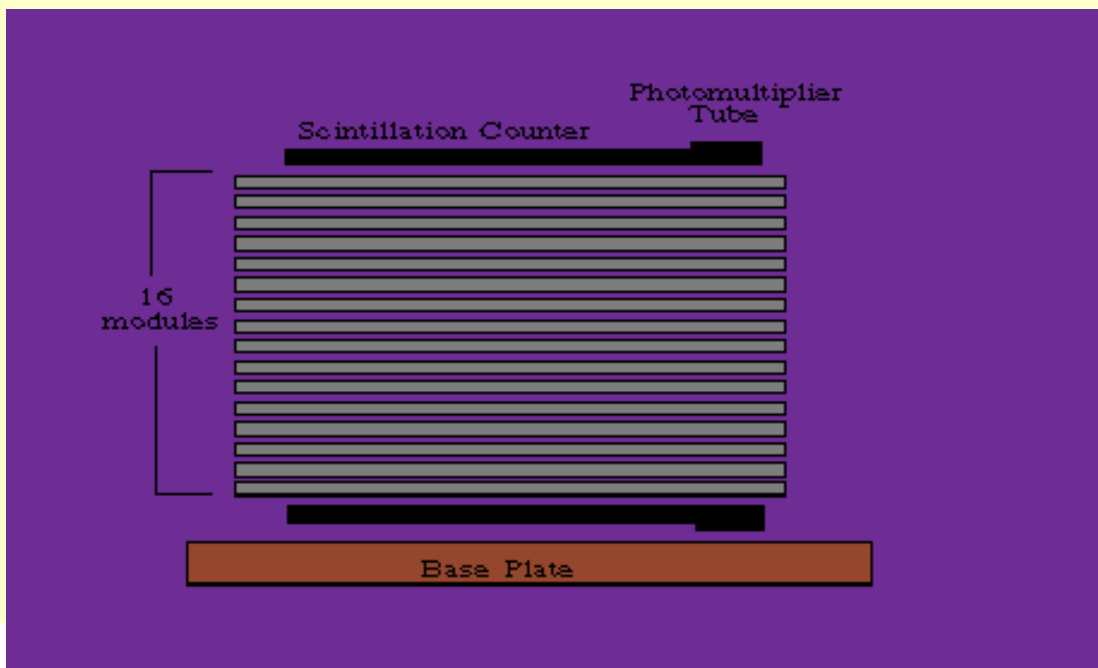

Parts of sparkchamber setup

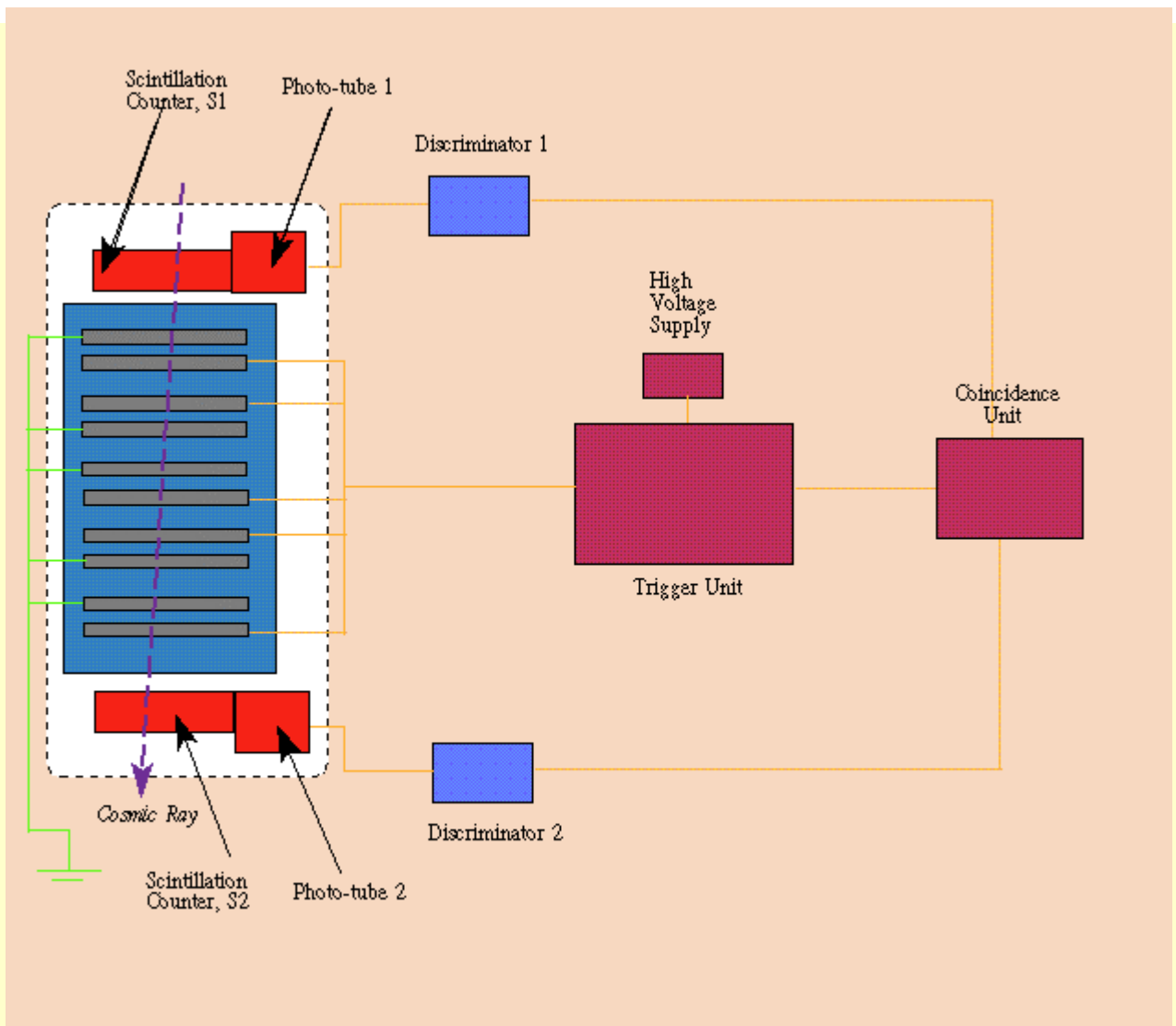

What we see in spark chamber

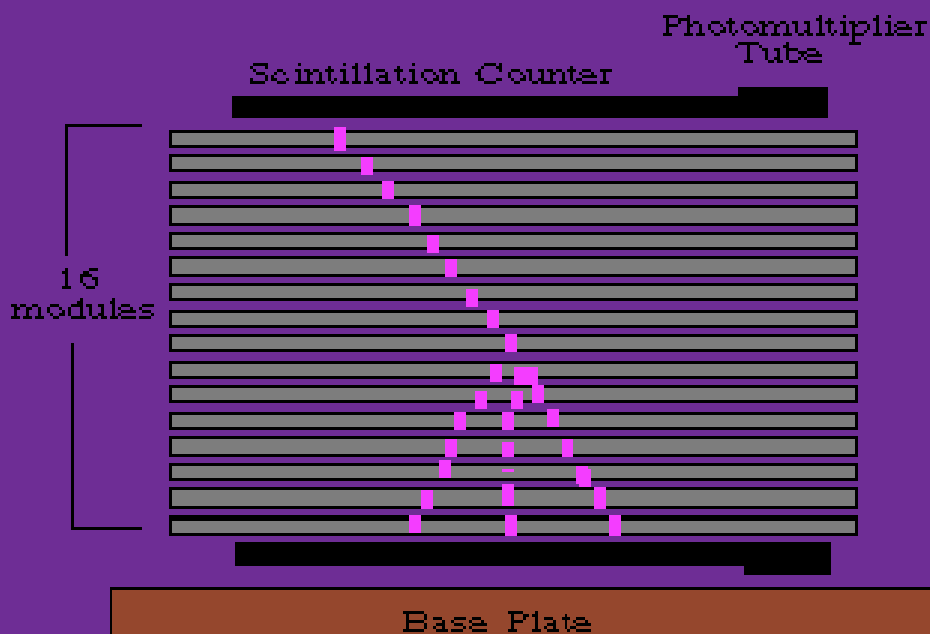
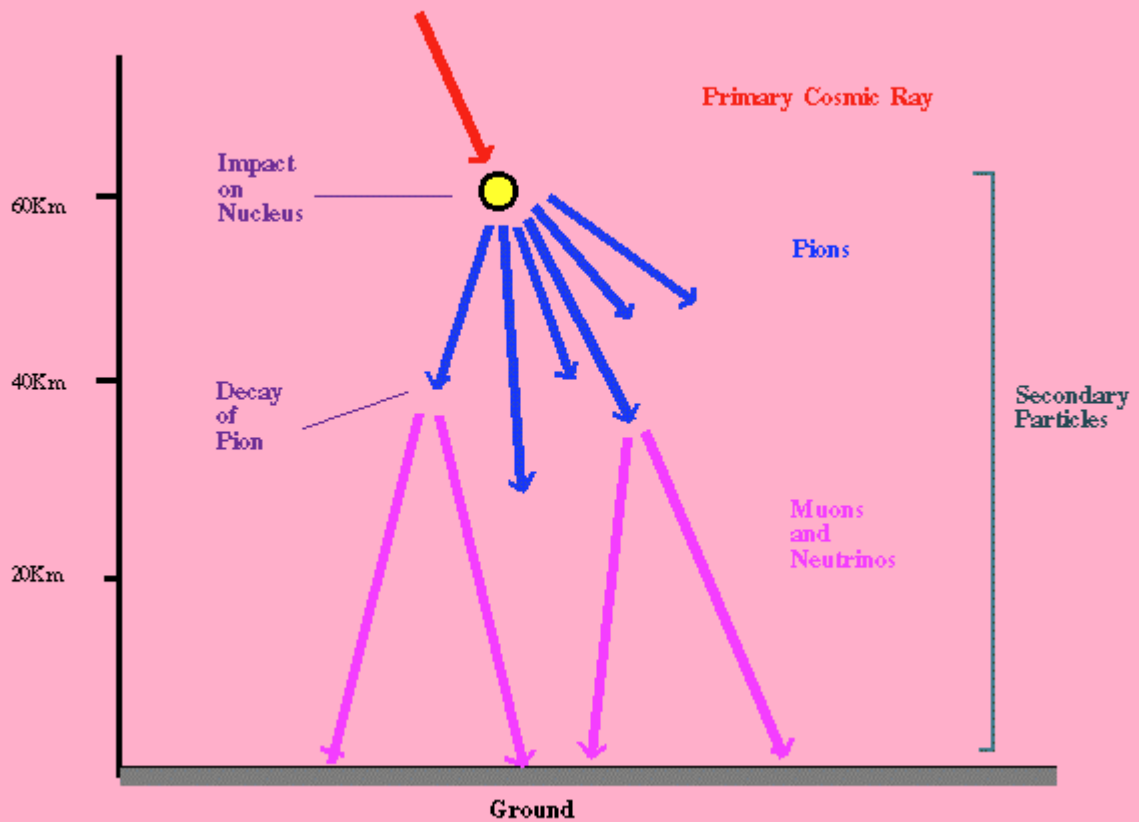

Geiger-Müller counter:

- metallic tube with thin wire in center, filled with gas, HV between wall (-, "cathode") and central wire (+, "anode"); \Rightarrow strong electric field near wire;
- charged particle in gas \Rightarrow ionization \Rightarrow electrons liberated;
- electrons accelerated in electric field \Rightarrow liberate other electrons by ionization which in turn are accelerated and ionize \Rightarrow "avalanche of electrons"; avalanche becomes so big that all of gas ionized \Rightarrow plasma formation \Rightarrow discharge
- gas is usually noble gas (e.g. argon), with some additives e.g. carbon dioxide, methane, isobutane,..) as "quenchers";

Geiger Counter Principles

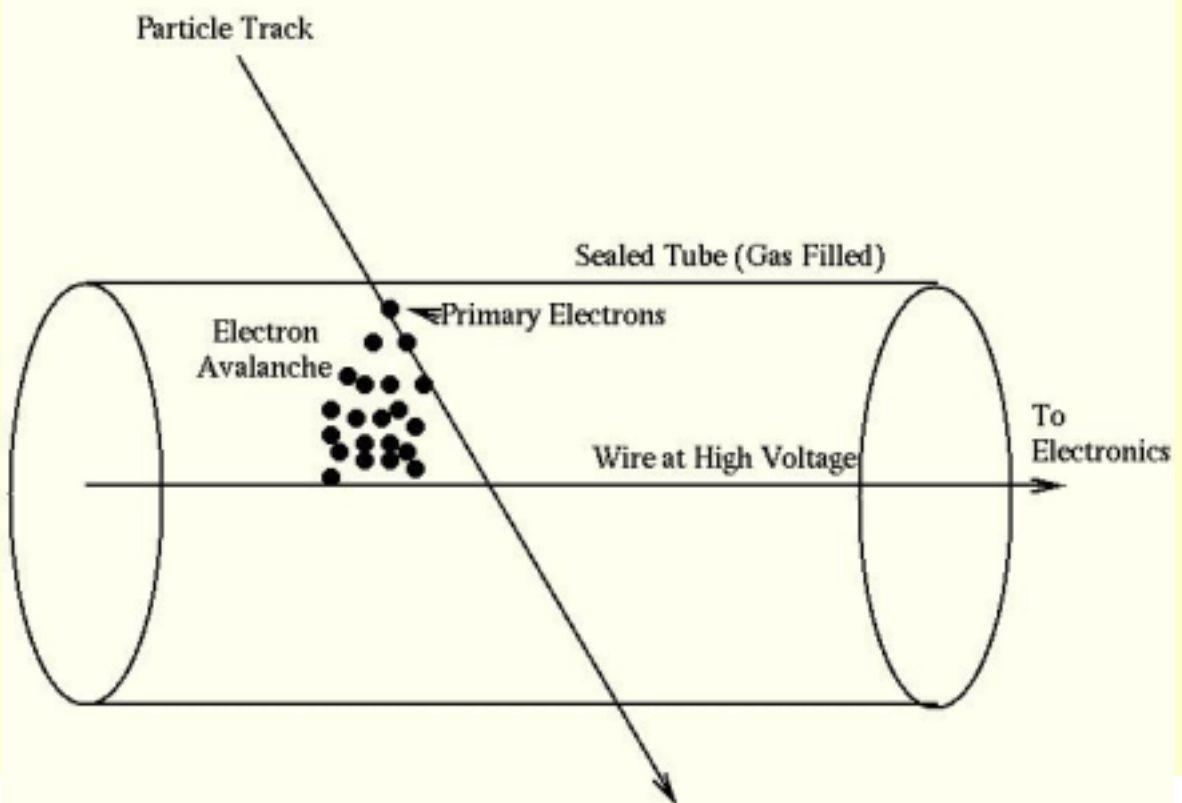

Cloud chamber

- Container filled with gas (e.g. air), plus vapor close to its dew point (saturated)
- Passage of charged particle \Rightarrow ionization;
- Ions form seeds for condensation \Rightarrow condensation takes place along path of particle \Rightarrow path of particle becomes visible as chain of droplets

Cloud Chamber Reveals Tracks of Charged Particles

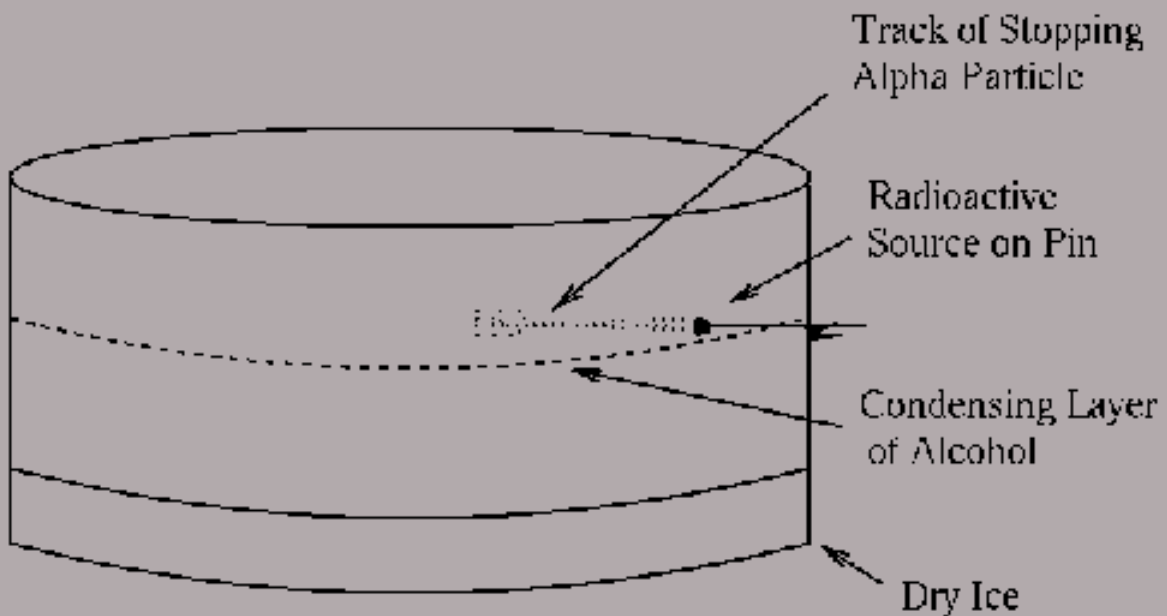

Positron discovery

- Positron (anti-electron)
 - predicted by Dirac (1928) -- needed for relativistic quantum mechanics
 - existence of antiparticles doubled the number of known particles!!!

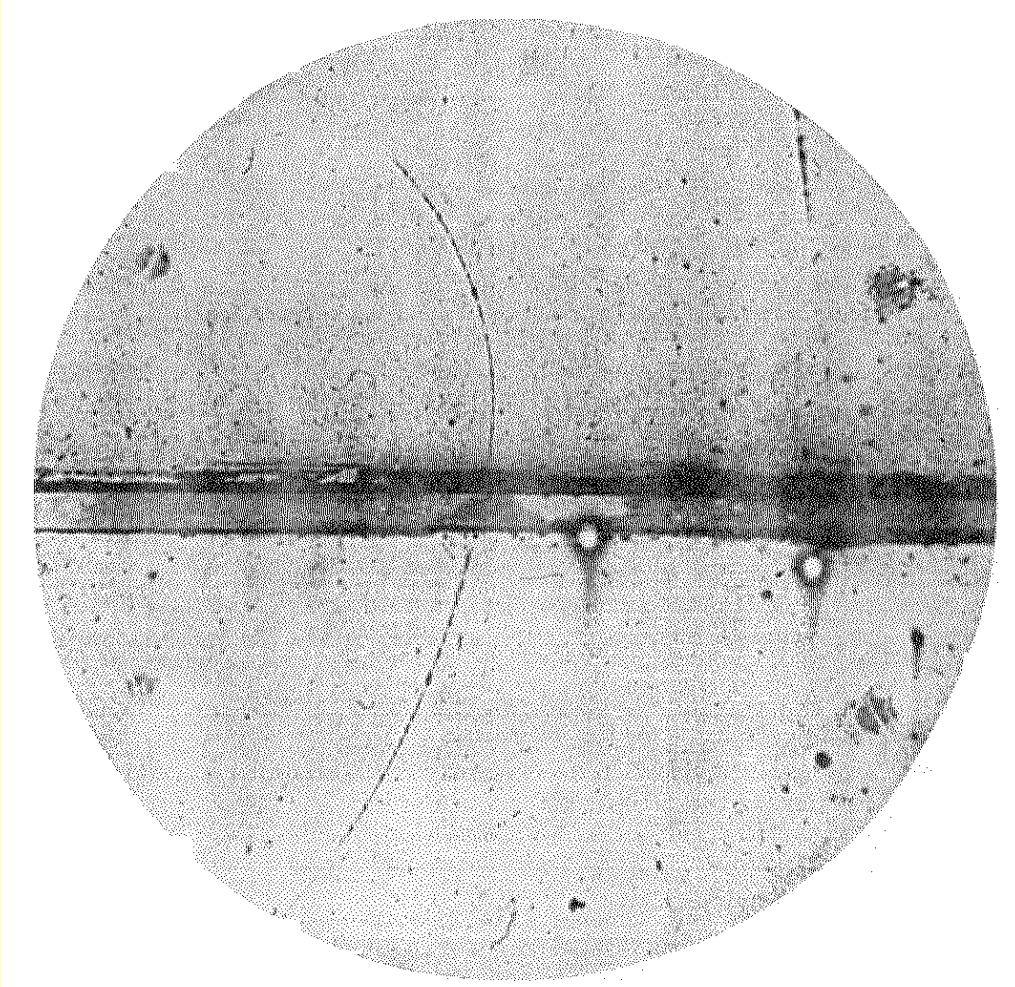

- positron track going upward through lead plate
 - ◆ photographed by Carl Anderson (August 2, 1932), while photographing cosmic-ray tracks in a cloud chamber
 - ◆ particle moving upward, as determined by the increase in curvature of the top half of the track after it passed through the lead plate,
 - ◆ and curving to the left, meaning its charge is positive.

Anderson and his cloud chamber

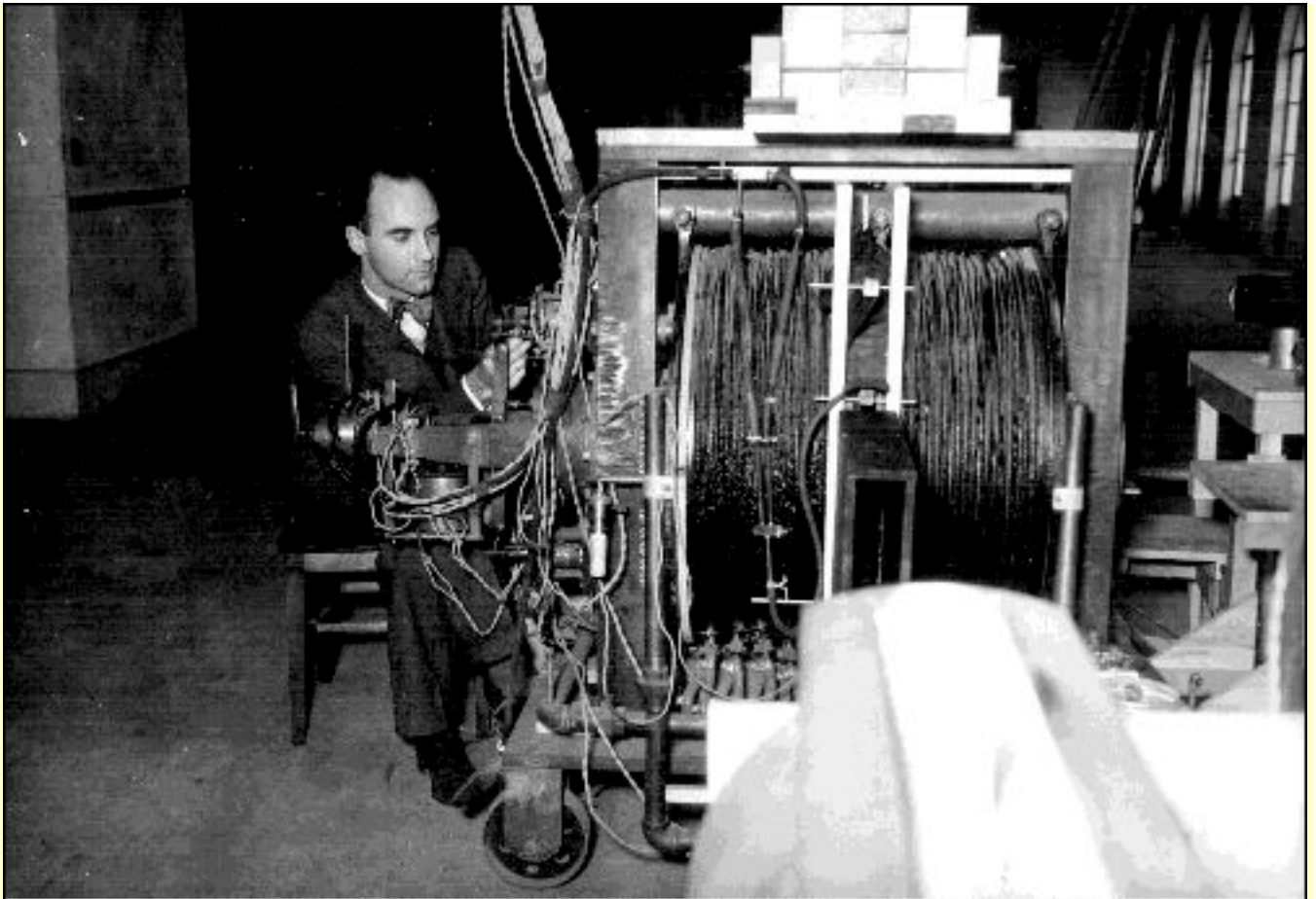

© Copyright California Institute of Technology. All rights reserved.
Commercial use or modification of this material is prohibited.

Bubble chamber

- bubble chamber
 - Vessel, filled (e.g.) with liquid hydrogen at a temperature above the normal boiling point but held under a pressure of about 10 atmospheres by a large piston to prevent boiling.
 - When particles have passed, and possibly interacted in the chamber, the piston is moved to reduce the pressure, allowing bubbles to develop along particle tracks.
 - After about 3 milliseconds have elapsed for bubbles to grow, tracks are photographed using flash photography. Several cameras provide stereo views of the tracks.
 - The piston is then moved back to recompress the liquid and collapse the bubbles before boiling can occur.
- Invented by Glaser in 1952 (when he was drinking beer)

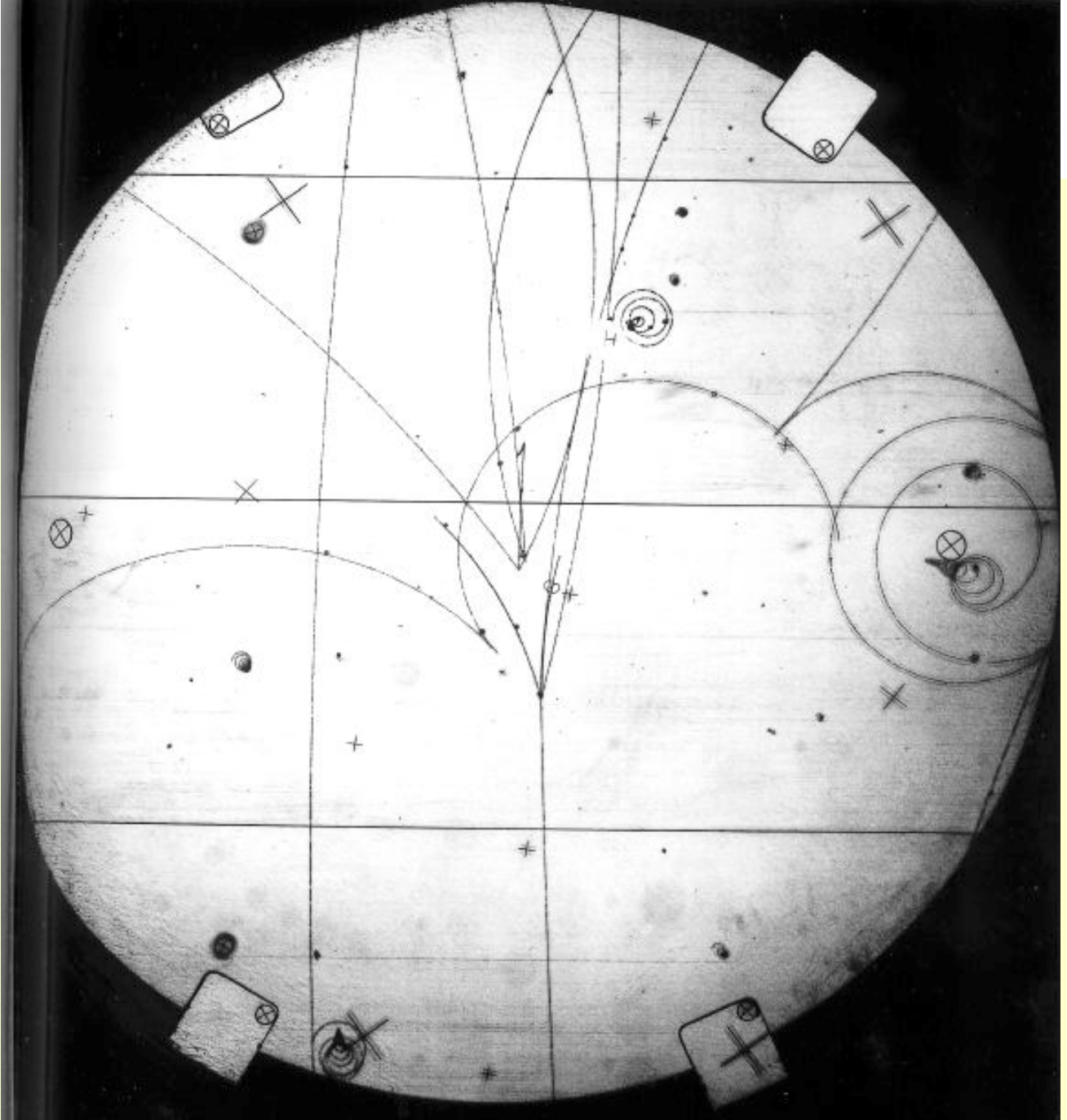

- $\bar{p} p \rightarrow p \bar{n} K^0 K^- \pi^+ \pi^- \pi^0$
- $\bar{n} + p \rightarrow 3 \text{ pions}$
- $\pi^0 \rightarrow \gamma\gamma, \gamma \rightarrow e^+ e^-$
- $K^0 \rightarrow \pi^+ \pi^-$

"Strange particles"

- Kaon: discovered 1947; first called "V" particles

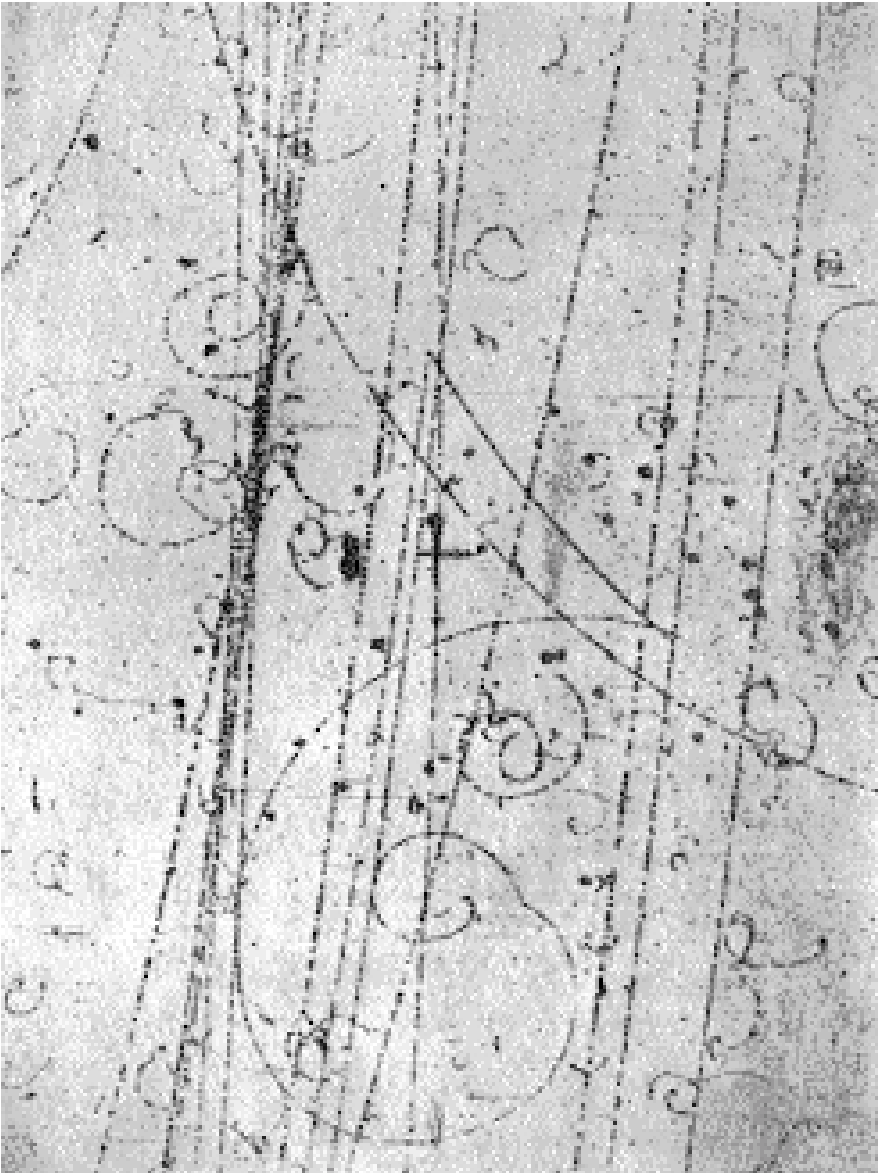

K^0 production and decay
in a bubble chamber

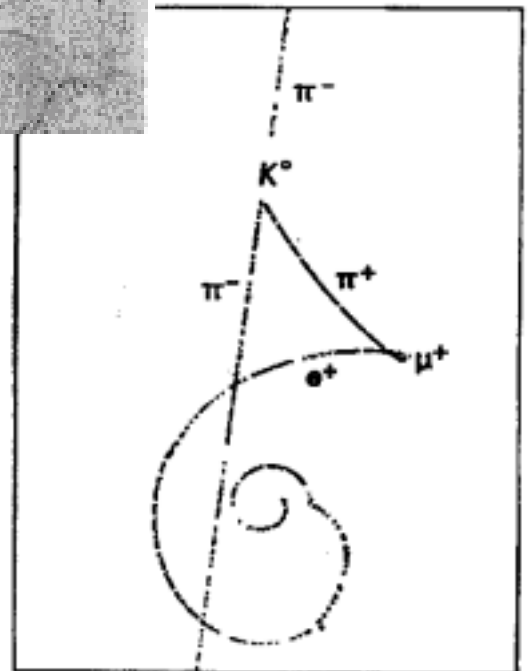

Proportional tube

- proportional tube:
 - similar in construction to Geiger-Müller counter, but works in different HV regime
 - metallic tube with thin wire in center, filled with gas, HV between wall (-, "cathode") and central wire (+, "anode"); \Rightarrow strong electric field near wire;
 - charged particle in gas \Rightarrow ionization \Rightarrow electrons liberated;
 - electrons accelerated in electric field \Rightarrow can liberate other electrons by ionization which in turn are accelerated and ionize \Rightarrow "avalanche of electrons" moves to wire \Rightarrow current pulse; current pulse amplified \Rightarrow electronic signal;
 - gas is usually noble gas (e.g. argon), with some additives e.g. carbon dioxide, methane, isobutane,..) as "quenchers";

Wire chambers

- multi wire proportional chamber:
 - contains many parallel anode wires between two cathode planes (array of prop.tubes with separating walls taken out)
 - operation similar to proportional tube;
 - cathodes can be metal strips or wires \Rightarrow get additional position information from cathode signals.

- drift chamber:
 - field shaping wires and electrodes on wall to create very uniform electric field, and divide chamber volume into "drift cells", each containing one anode wire;
 - within drift cell, electrons liberated by passage of particle move to anode wire, with avalanche multiplication near anode wire;
 - arrival time of pulse gives information about distance of particle from anode wire; ratio of pulses at two ends of anode wire gives position along anode wire;

Particle detectors, cont'd

- Cherenkov detector:
 - measure Cherenkov light (amount and/or angle) emitted by particle going through counter volume filled with transparent gas, liquid, aerogel, or solid
⇒ get information about speed of particle.
- calorimeter:
 - “destructive” method of measuring a particle's energy: put enough material into particle's way to force formation of electromagnetic or hadronic shower (depending on kind of particle)
 - eventually particle loses all of its energy in calorimeter;
 - energy deposit gives measure of original particle energy.
- Note: *many of the detectors and techniques developed for particle and nuclear physics are now being used in medicine, mostly diagnosis, but also for therapy.*

Calorimeters

- Principle:
 - Put enough material into particle path to force development of electromagnetic or hadronic shower (or mixture of the two).
- Total absorption calorimeter:
 - depth of calorimeter sufficient to “contain” showers originating from particle of energy lower than design energy
 - depth measured in “radiation lengths” for e.m. and “nuclear absorption lengths” for hadronic showers
 - most modern calorimeters are “sampling calorimeters” – separate layers of high density material (“absorber”) to force shower development, and “sensitive” layer to detect charged particles in the shower.
 - total visible path length of shower particles is proportional to total energy deposited in calorimeter
 - segmentation allows measurement of positions of energy deposit
 - lateral and longitudinal energy distribution different for hadronic and e.m. showers – used for identification
 - absorber materials: U, W, Pb, Fe, Cu,..
 - sensitive medium: scintillator, silicon, liquid argon,..

Identifying particles

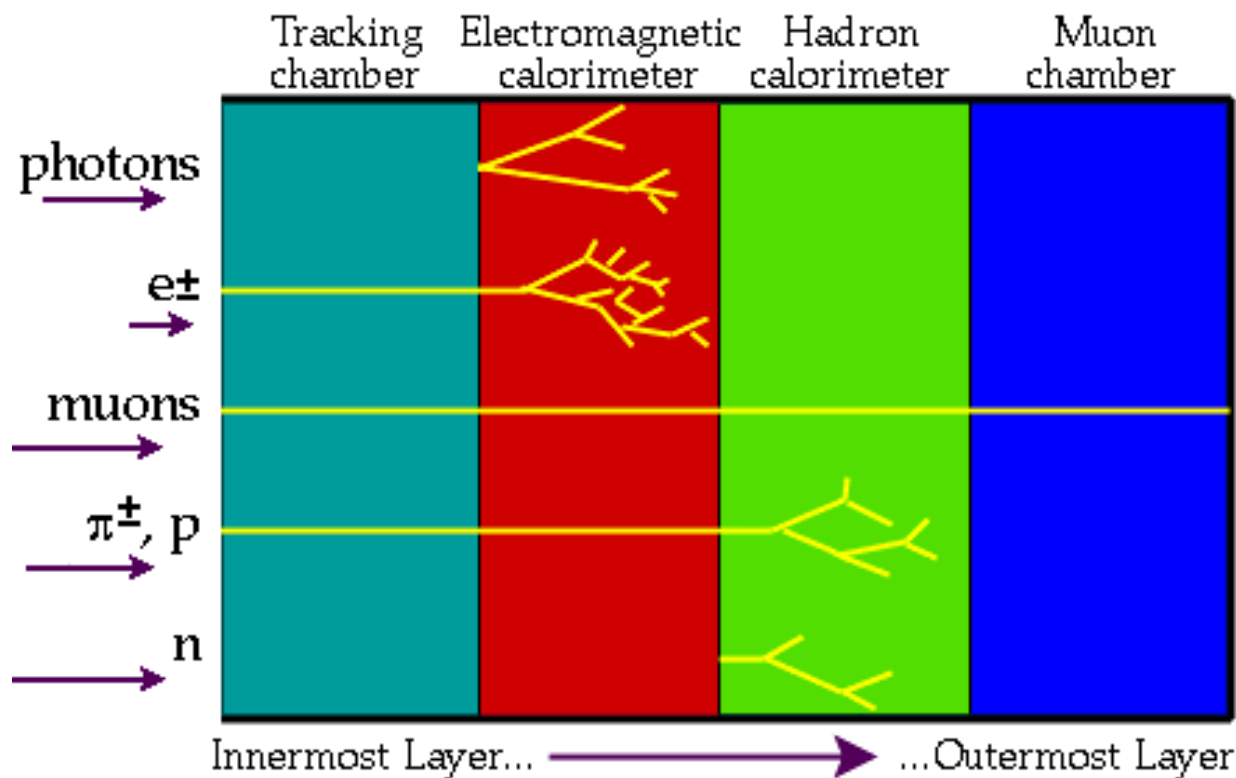

A detector cross-section, showing particle paths

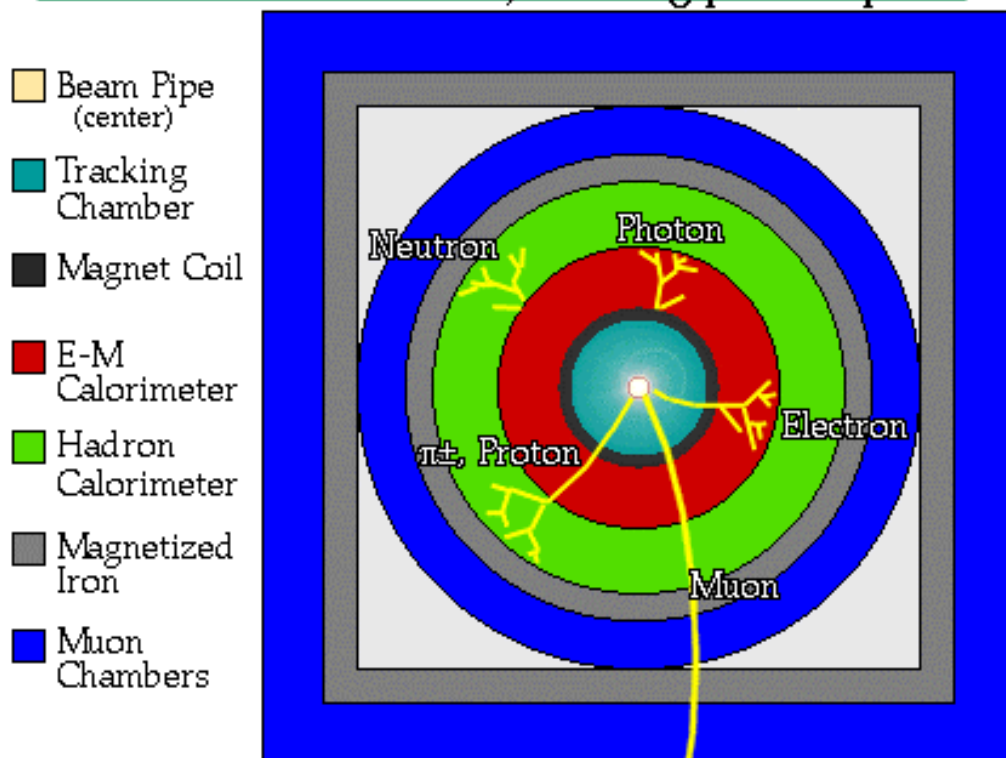

Particle Identification

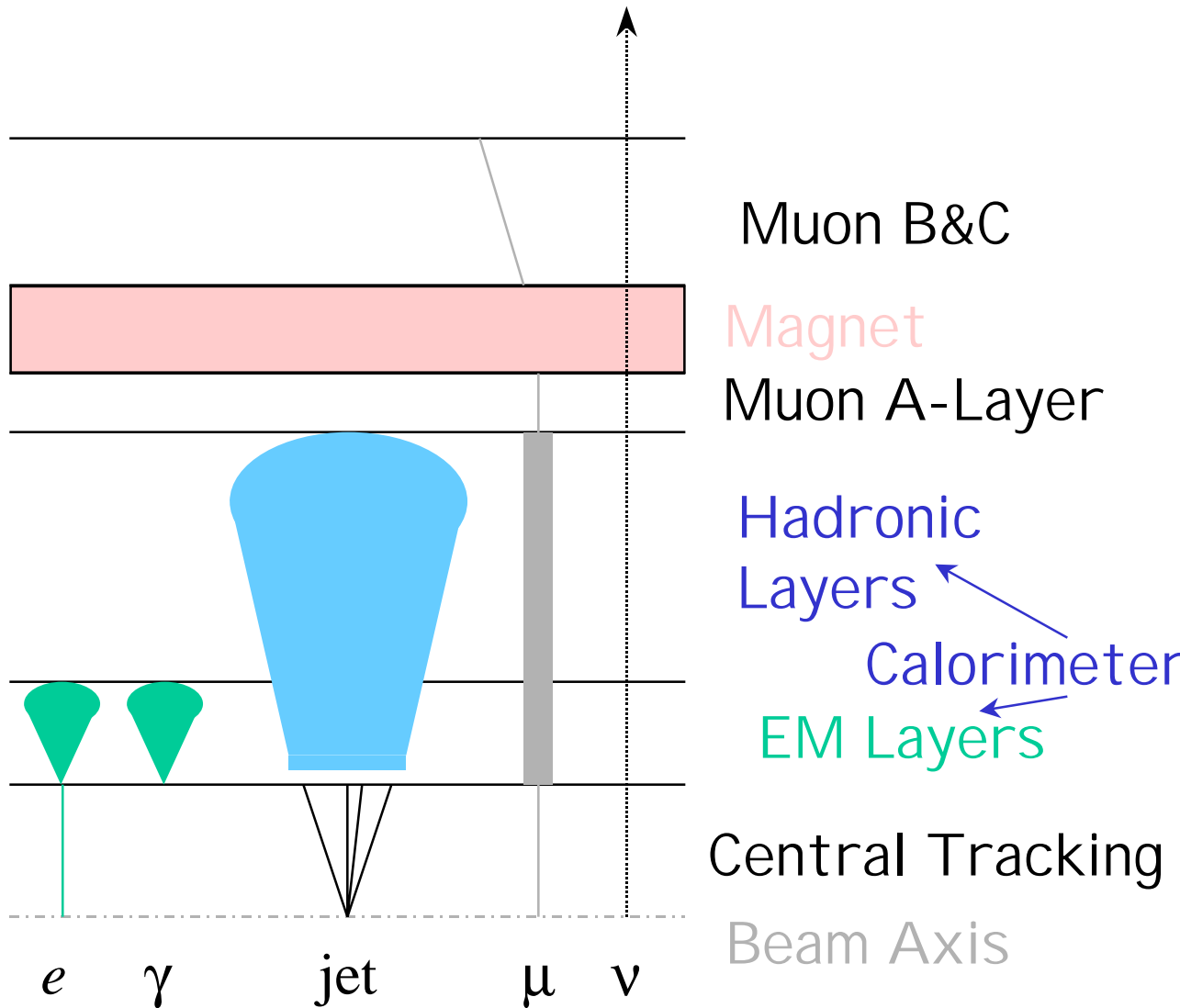

What do we actually "see" in a top event

$$t\bar{t} \rightarrow e\mu + jets$$

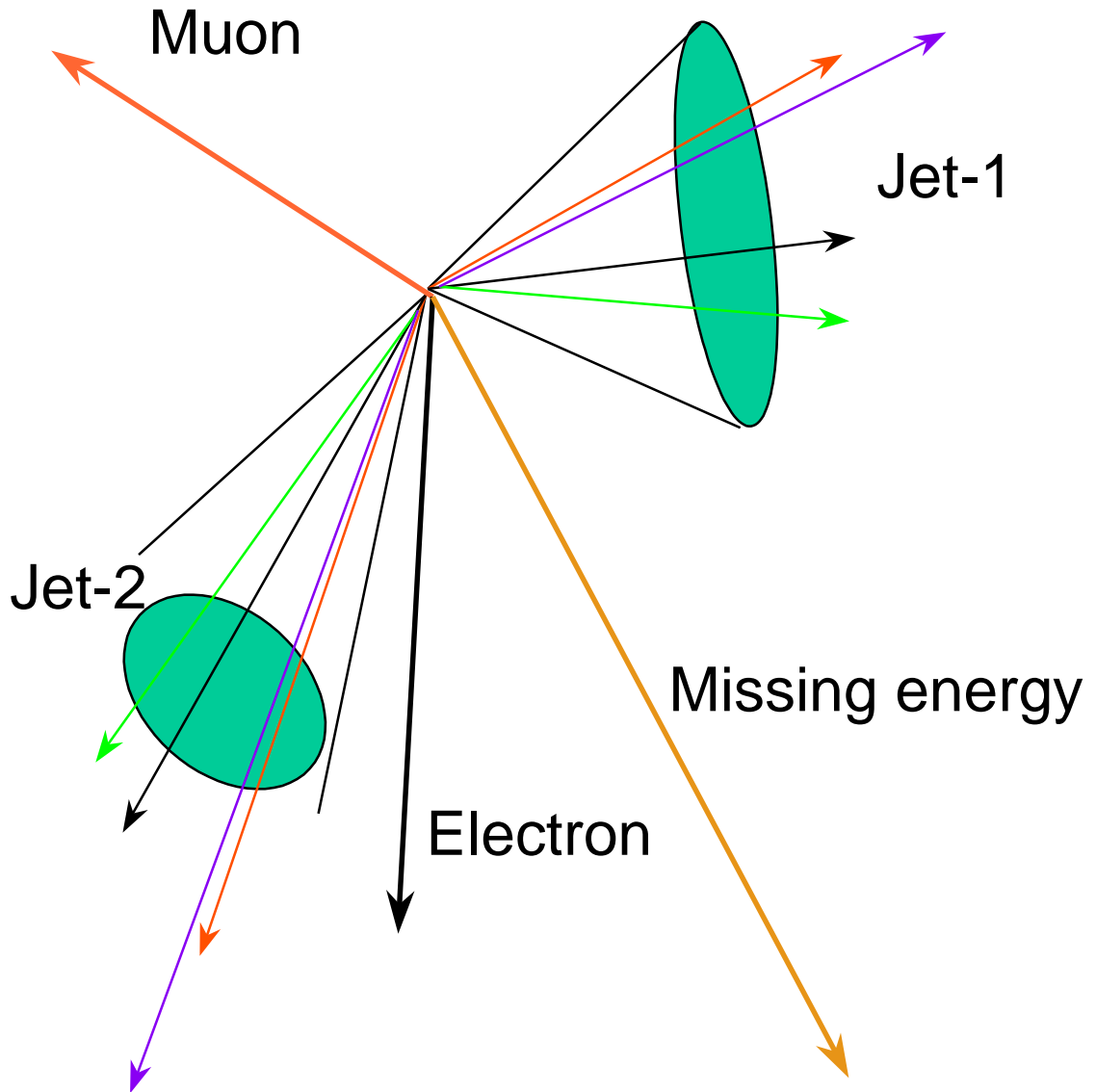

Silicon detectors

- Silicon has properties which make it especially desirable as a detector material
 - low ionization energy (good signal)
 - long mean free path (good charge collection efficiency)
 - high mobility (fast charge collection)
 - low Z (low multiple scattering)
 - Very well developed technology

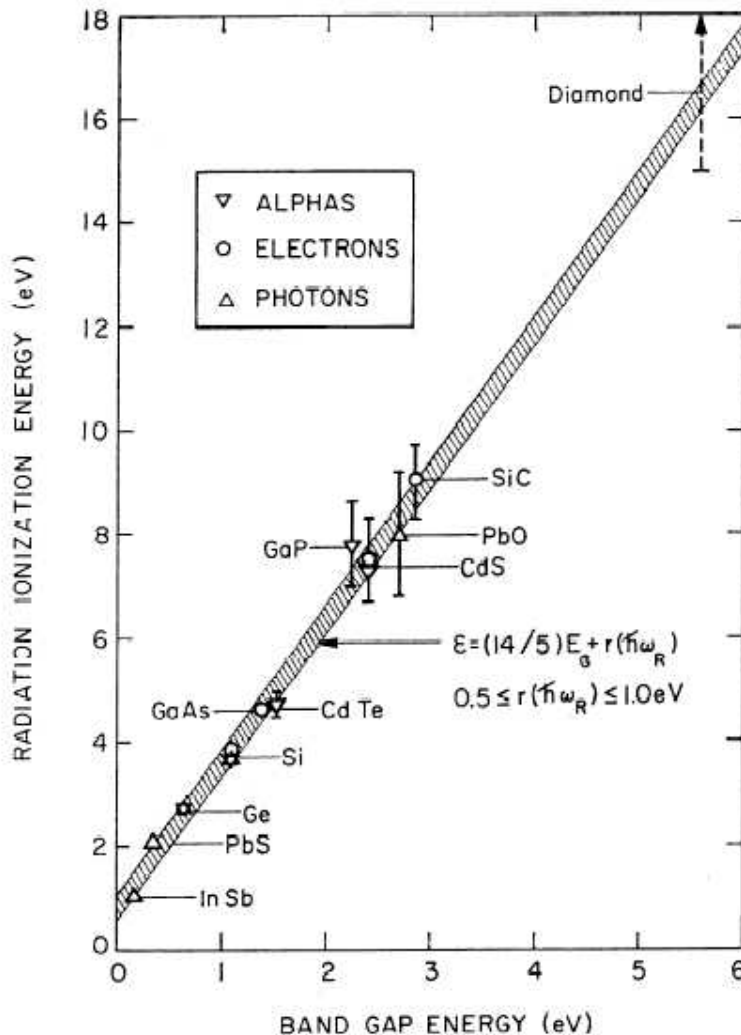

Diode depletion

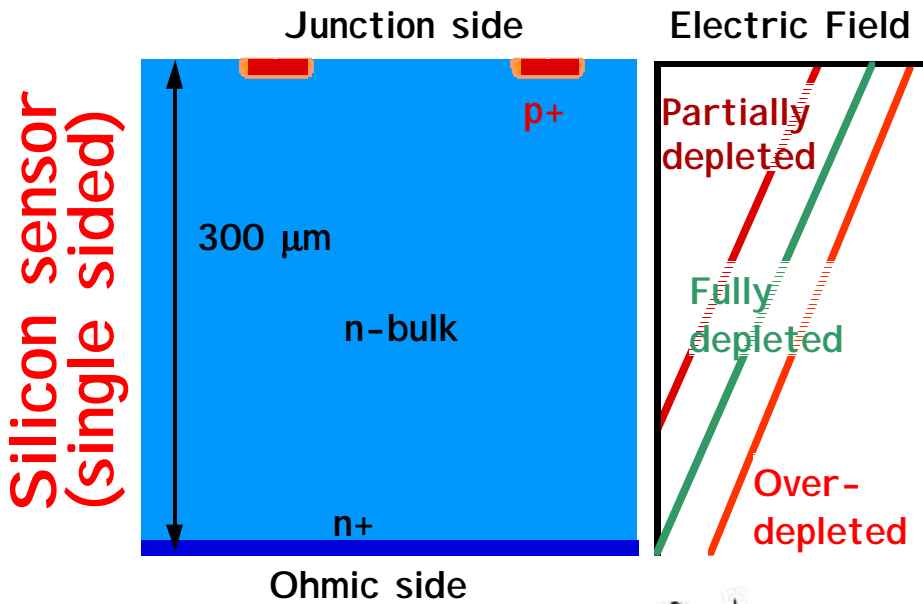

Silicon detectors have:

- lightly doped bulk (usually n)
- heavily doped contacts
- unusually large depleted area.
- Diffusion of charge carriers will form a local depleted region with no applied voltage

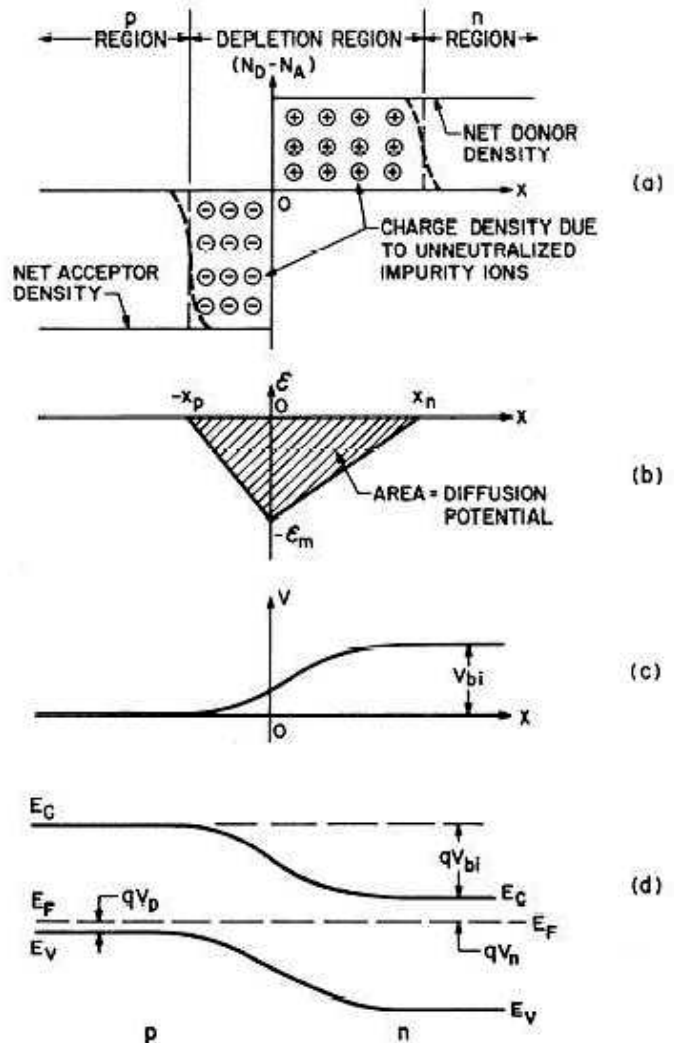

(from Sze, *Physics of Semiconductor Devices*)

Solid State Detector Physics - band structures

- Silicon detectors are typically high resistivity $>1 \text{ K}\Omega\text{-cm}$ "float zone" silicon
- The small energy gap between impurity "donor" or "acceptor" levels means most mobile electrons and holes are due to dopants.

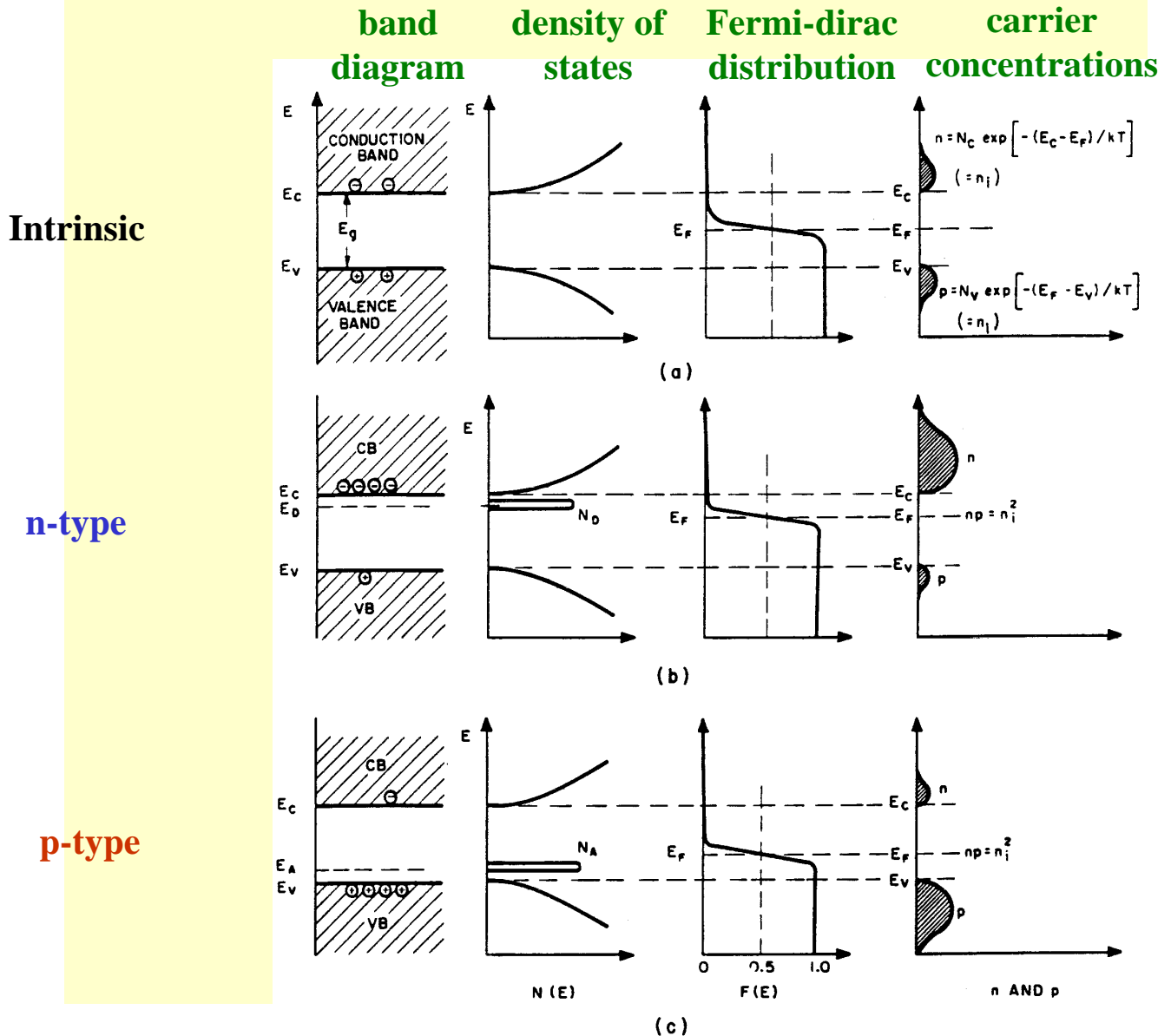

Fig. 14 Schematic band diagram, density of states, Fermi-Dirac distribution, and the carrier concentrations for (a) intrinsic, (b) n-type, and (c) p-type semiconductors at thermal equilibrium. Note that $pn = n_i^2$ for all three cases.

Solid State Detector Physics - device characteristics

Resistivity:
$$\rho = \frac{1}{q(\mu_n N_n + \mu_p N_p)}$$

Depletion voltage:
$$d = \sqrt{\frac{2\epsilon V_{bias}}{qN_{eff}}} \quad V_{fd} = \frac{N_{eff} q D^2}{2\epsilon}$$

Electric Field:
$$E(x) = \frac{2V_{fd}}{D} \left(1 - \frac{x}{D}\right) + \frac{V_{bias} - V_{fd}}{D}$$

$\mu_{e,h}$ = electron, hole mobility

N_{eff} = Effective carrier concentration

x = distance from junction D = silicon thickness

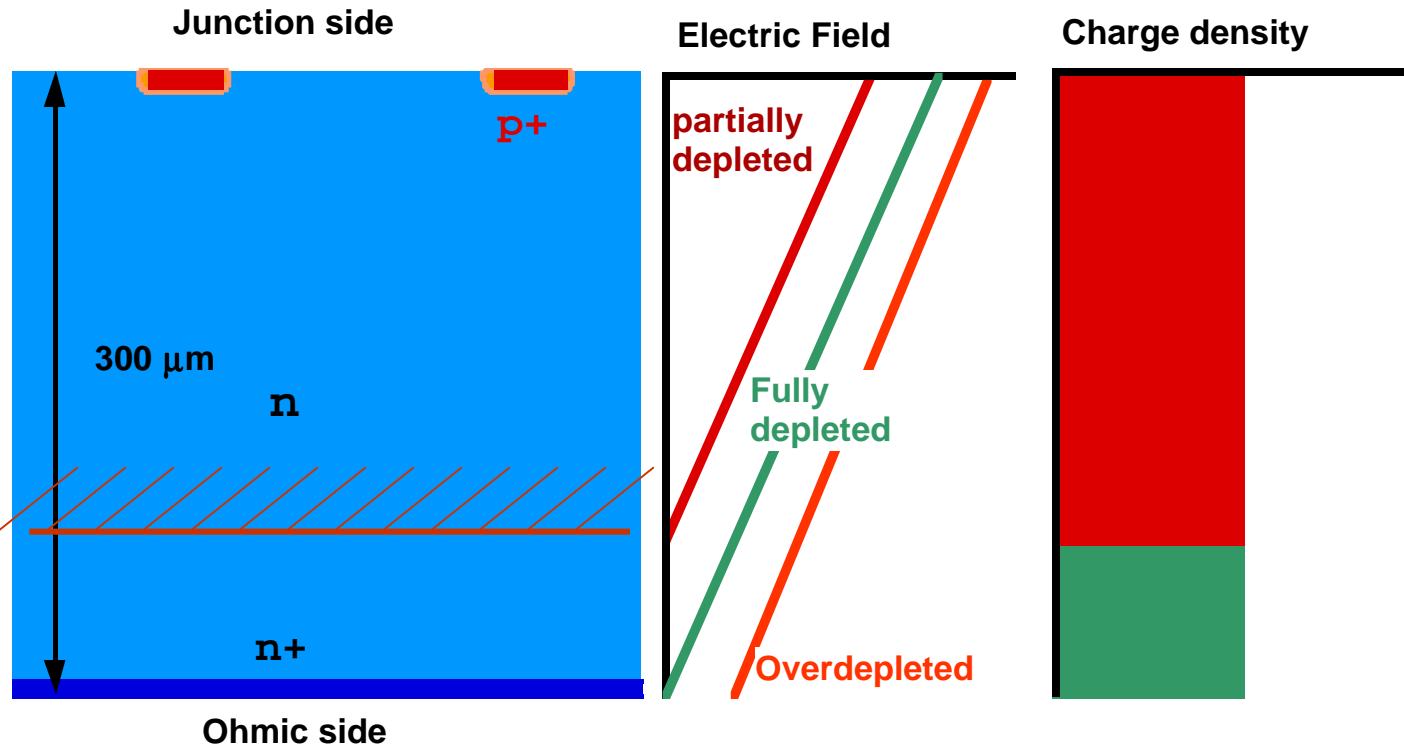

The D0 detector

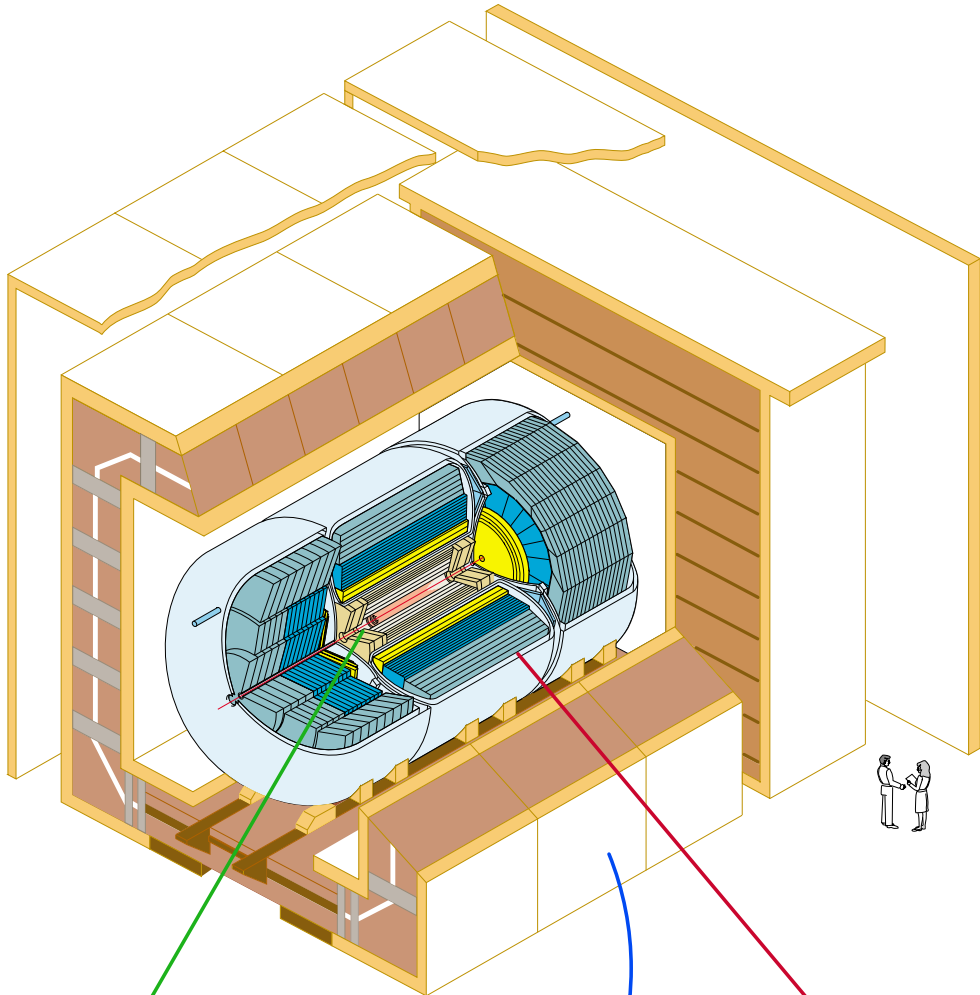

TRACKING

$\sigma(z \text{ vertex}) = 6 \text{ mm}$
 $\sigma(r\phi) = 60 \mu\text{m}$ (VTX)
 $= 180 \mu\text{m}$ (CDC)
 $= 200 \mu\text{m}$ (FDC)

MUON

$|\eta| < 3.3$

$\frac{\delta p}{p} = 0.2 \oplus 0.01p$

CALORIMETRY

$|\eta| < 4$

$\Delta\eta \times \Delta\phi = 0.1 \times 0.1$

$\sigma(\text{EM}) = 15\% / \sqrt{E}$

$\sigma(\text{HAD}) = 50\% / \sqrt{E}$

DØ Calorimeter

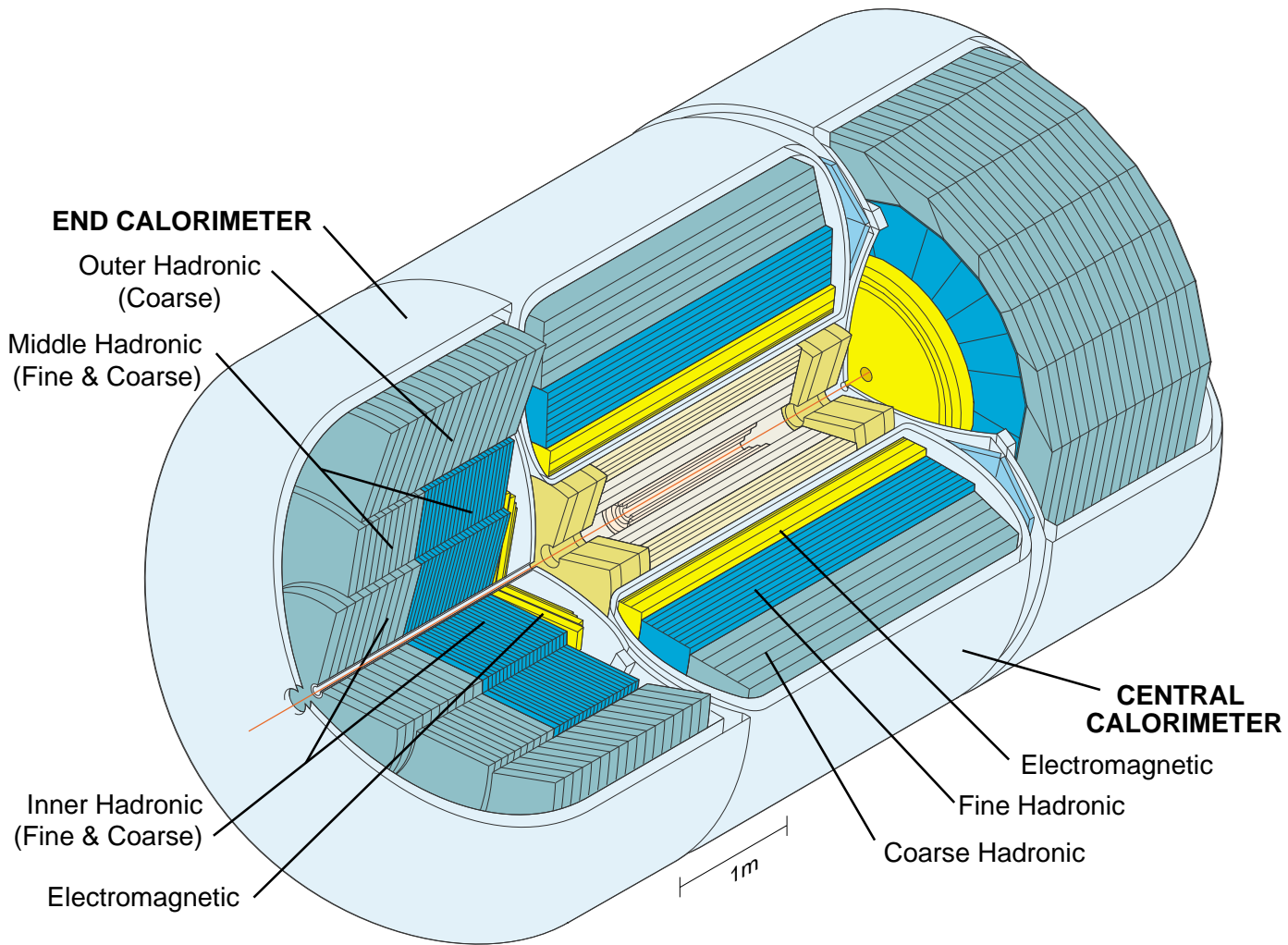

- Uranium-Liquid Argon sampling calorimeter
 - Linear, hermetic, and compensating
- No central magnetic field!
 - Rely on EM calorimeter

DØ Upgrade

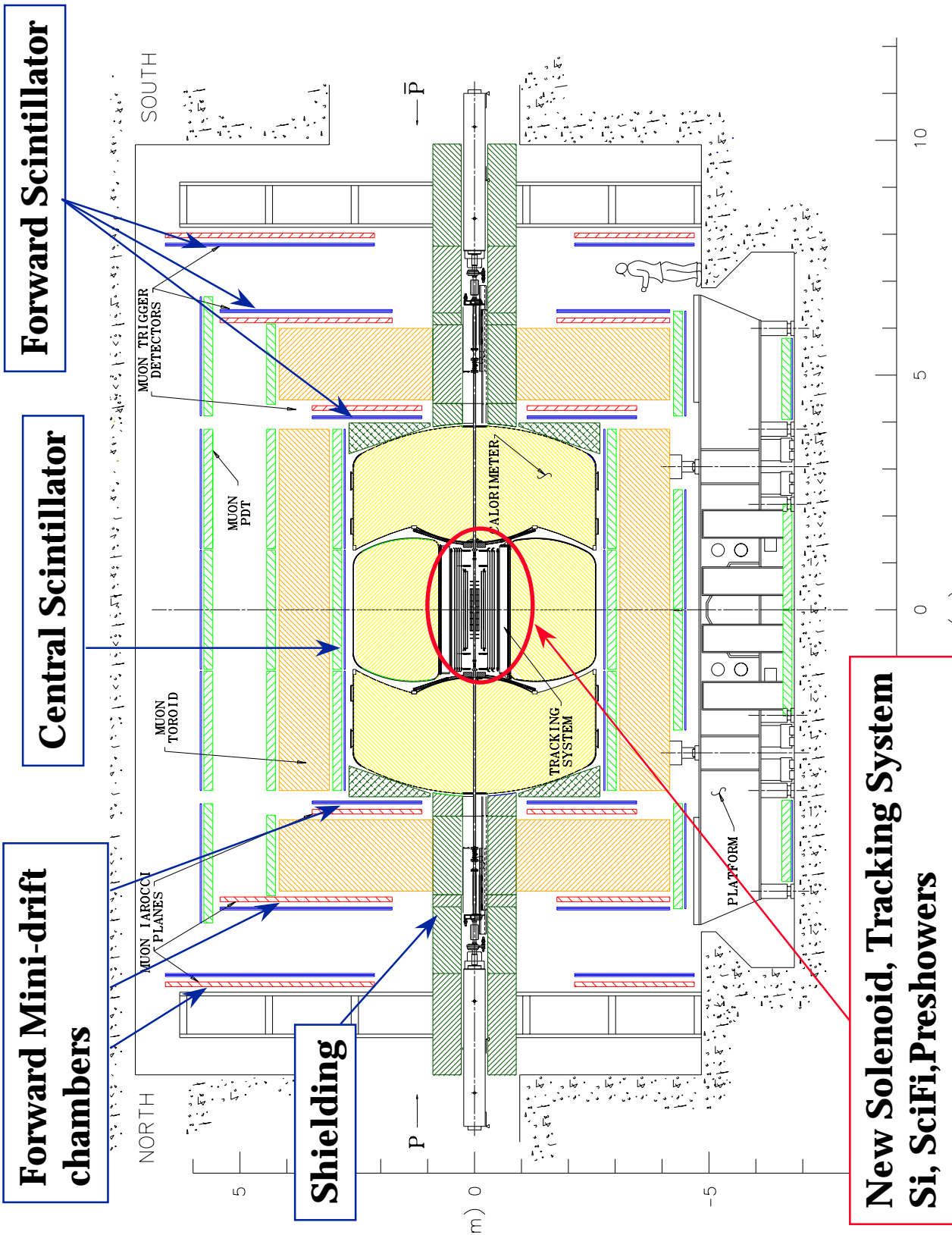

Forward Scintillator

Central Scintillator

Forward Mini-drift chambers

Shielding

**New Solenoid, Tracking System
Si, SciFi, Preshowers**

+ New Electronics, Trig, DAQ

Silicon Tracker

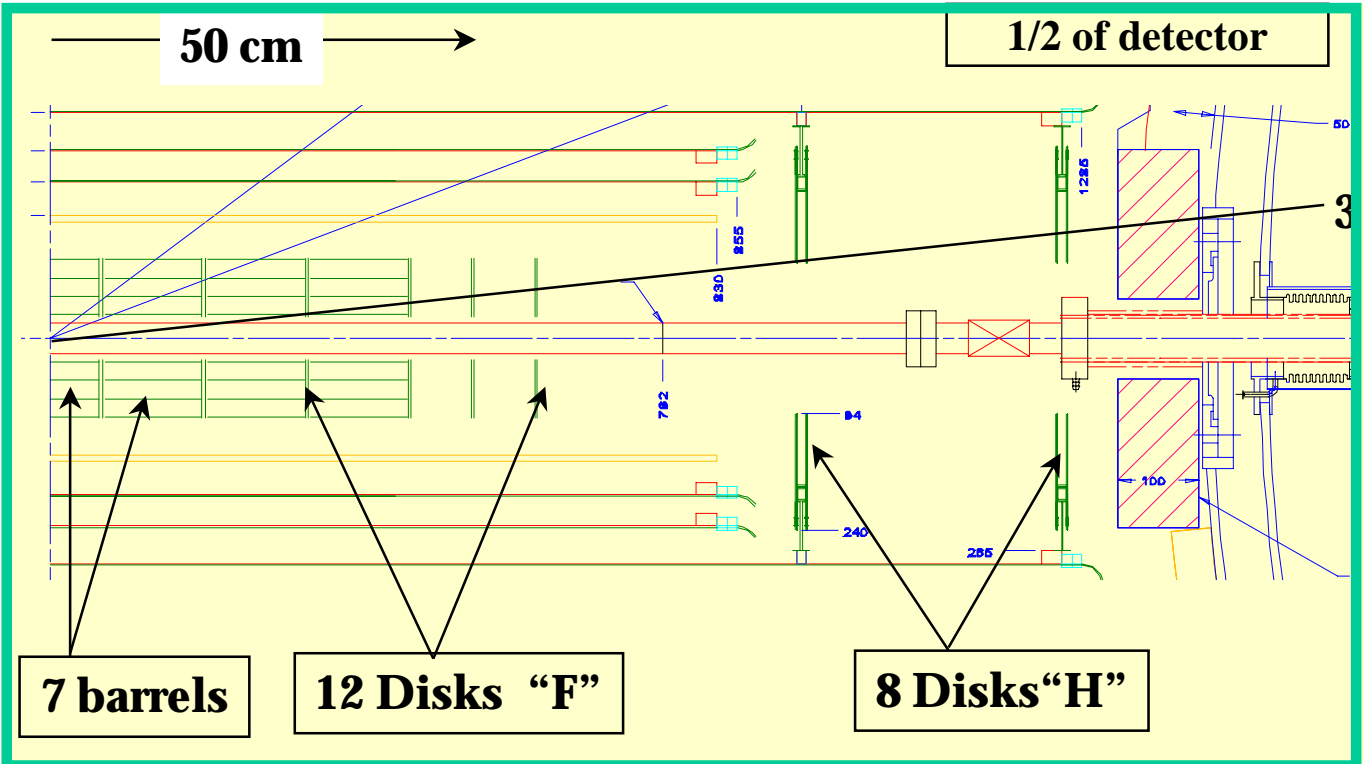

1/7 of the detector (large-z disks not shown)

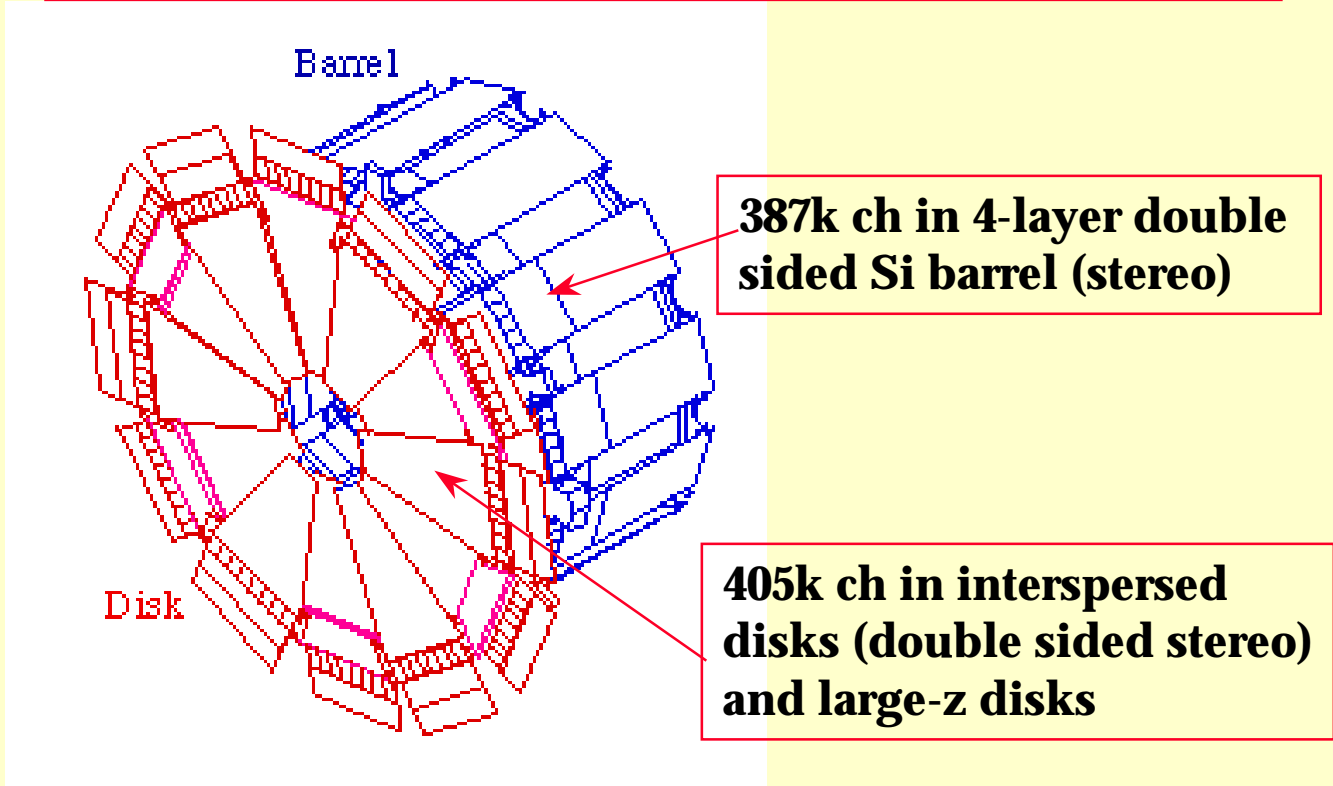

Silicon Tracker -Detectors

- Disks

- "F" disks wedge (small diameter):
 - ◆ 144 double sided detectors, 12 wedges = 1disk
 - ◆ 50 μ m pitch, +/-15 stereo
 - ◆ 7.5cm long, from r=2.5 to 10cm, at z=6,19,32,45,50,55 cm
- "H" disk (large diameter):
 - ◆ 384 single sided detectors
 - ◆ 50 μ m pitch
 - ◆ from r=9.5-20 cm, z= 94, 126 cm

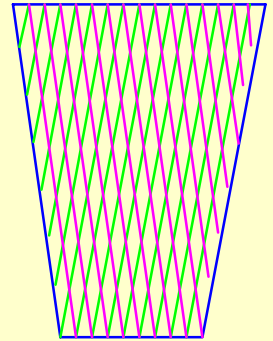

- Barrels

- 7 modular, 4 layer barrel segments
- single sided:
 - ◆ layers 1 , 3 in two outermost barrels.
- double sided:
 - ◆ layers 1, 3 have 90° stereo (mpx'd 3:1)
50 & 100 μ m pitch, 2.1 cm wide
 - ◆ layers 2,4 have small angle stereo (2°)
50 & 62.5 μ m pitch, 3.4 cm wide

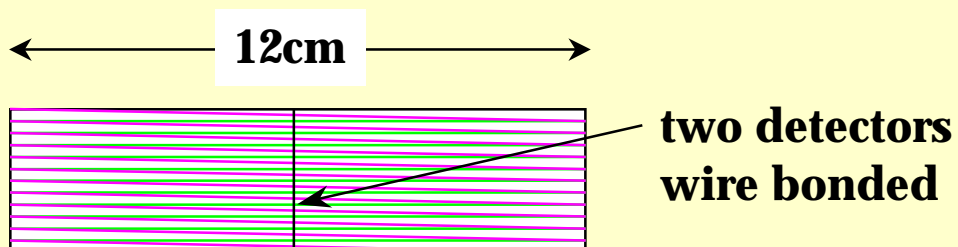

Trigger

- Trigger = device making decision on whether to record an event
- why not record all of them?
 - ◆ we want to observe “rare” events;
 - ◆ for rare events to happen sufficiently often, need high beam intensities \Rightarrow many collisions take place
 - ◆ e.g. in Tevatron collider, proton and antiproton bunches will encounter each other every 132ns
 - ◆ at high bunch intensities, every beam crossing gives rise to collision \Rightarrow
about 7 million collisions per second
 - ◆ we can *record about 20 to (maybe) 50 per second*
- why not pick 10 events randomly?
 - ◆ We would miss those rare events that we are really after:
 - e.g. top production: ≈ 1 in 10^{10} collisions
 - Higgs production: ≈ 1 in 10^{12} collisions
 - ◆ \Rightarrow would have to record 50 events/second for 634 years to get one Higgs event!
 - ◆ Storage needed for these events:
 $\approx 3 \times 10^{11}$ Gbytes
- Trigger has to decide fast which events not to record, without rejecting the “goodies”

Sample cross sections

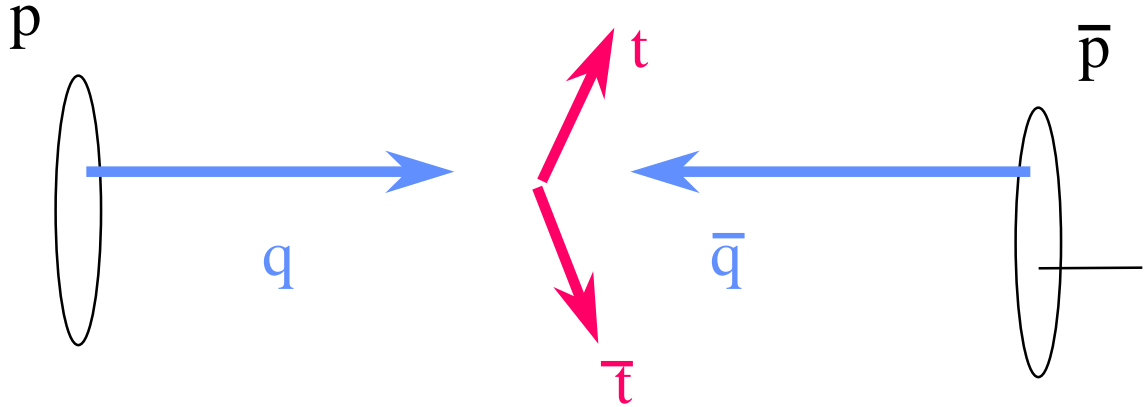

<u>Process</u>	<u>σ(pb)</u>		<u>events</u>
collision	8×10^{10}		8 trillion
2 jets	3×10^6		300 million
4 jets	125,000		12,500,000
6 jets	5,000		500,000
W	25,000	$\times 100 \text{ pb}^{-1}$	2,500,000
Z	11,000		1,100,000
WW	10		1000
tt	5		500
Higgs	0.1		10

Luminosity and cross section

- Luminosity is a measure of the beam intensity (particles per area per second)
($L \sim 10^{31} / \text{cm}^2 / \text{s}$)
- “integrated luminosity” is a measure of the amount of data collected (e.g. $\sim 100 \text{ pb}^{-1}$)
- cross section σ is measure of effective interaction area, proportional to the probability that a given process will occur.
 - ◆ 1 barn = 10^{-24} cm^2
 - ◆ 1 pb = $10^{-12} \text{ b} = 10^{-36} \text{ cm}^2 = 10^{-40} \text{ m}^2$
- interaction rate:

$$dn / dt = L \times \sigma \quad \Rightarrow \quad n = \sigma \int L dt$$

Trigger Configuration

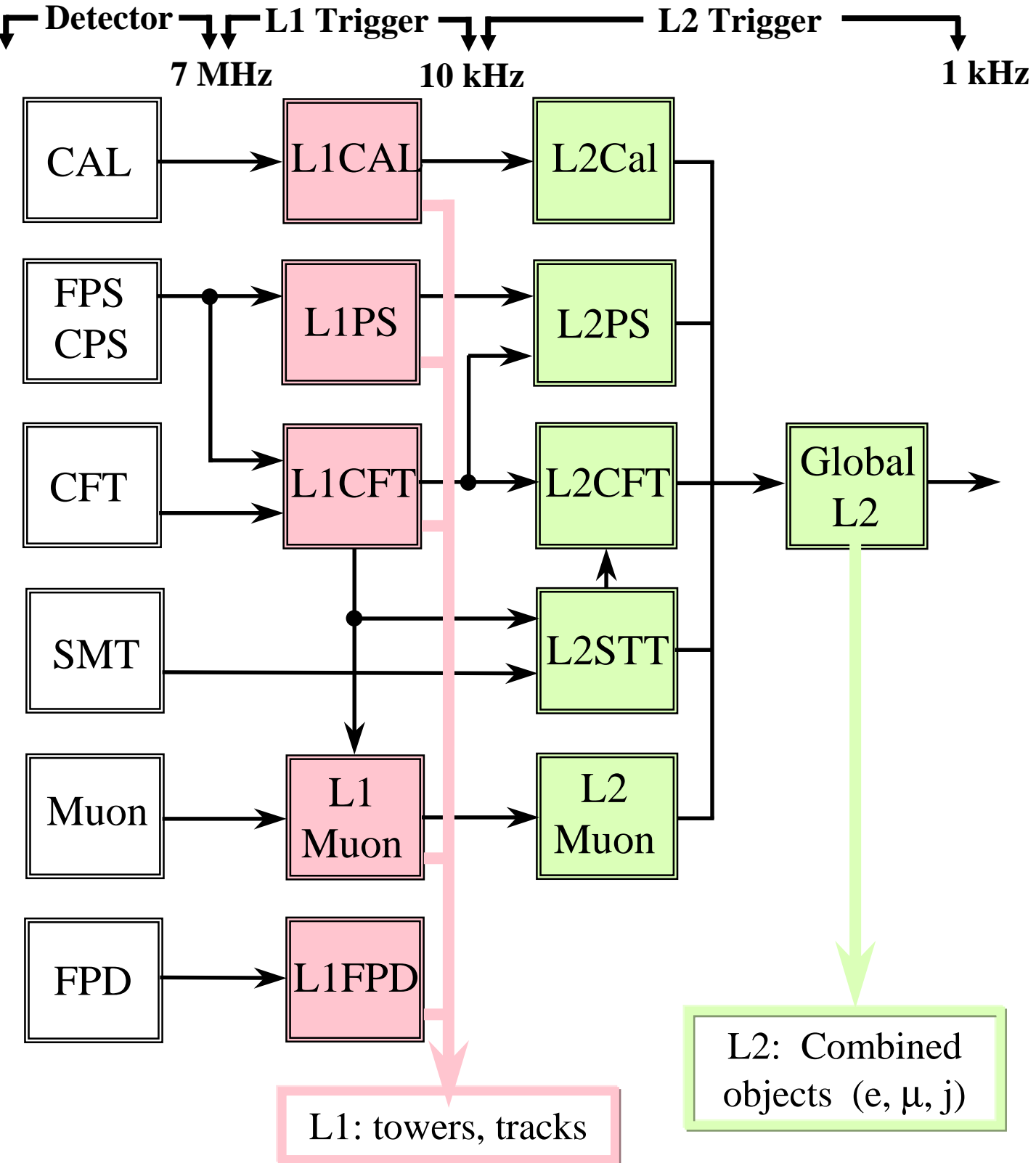

CMS Detector Subsystems

CMS A Compact Solenoidal Detector for LHC

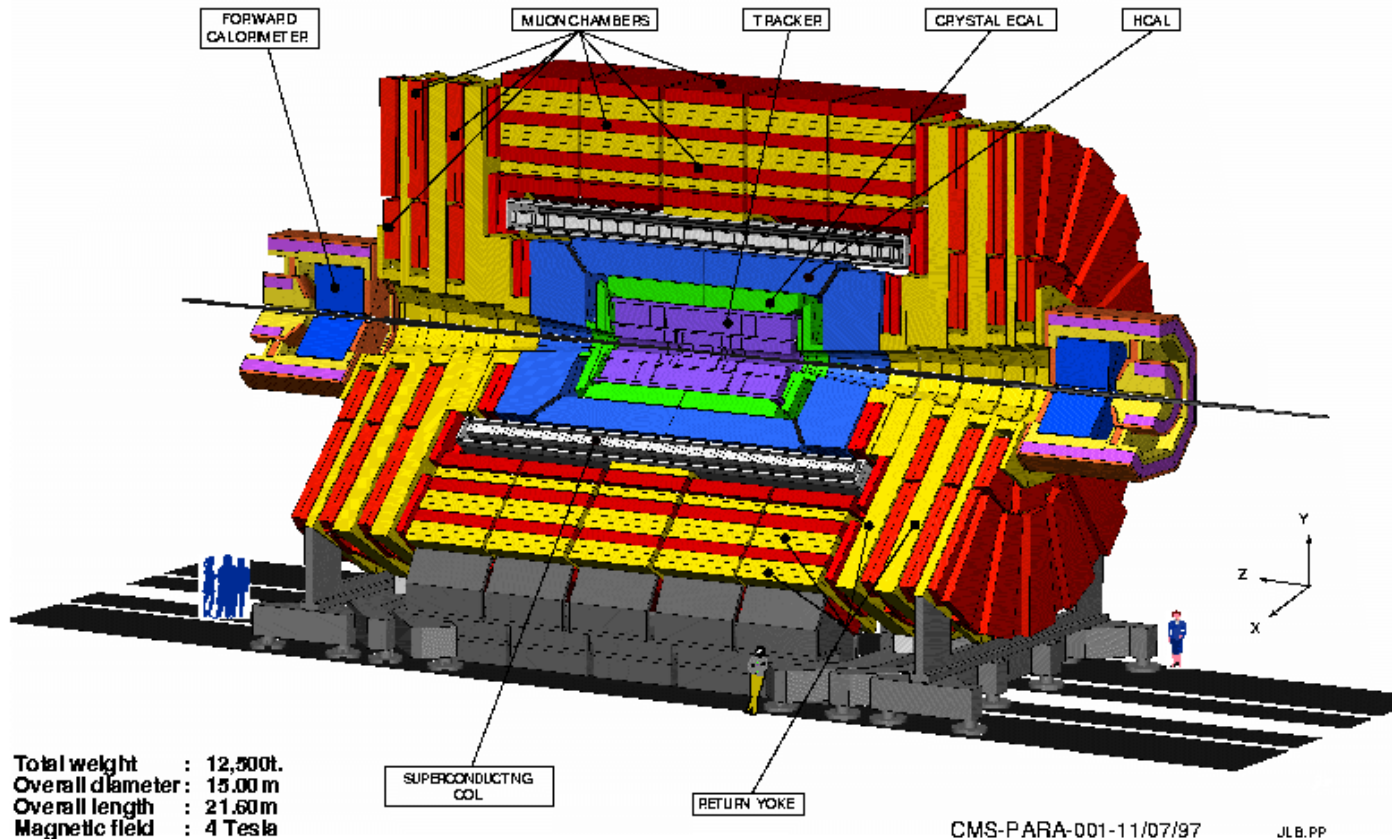

The CMS and US CMS Collaborations

Number of Laboratories

Member States	60
Non-Member States	38
USA	40
Total	138

Number of scientists

Member States	850
Non-Member States	389
USA	318
Total	1557

CMS Collaboration
557 Physicists & Engineers
31 Countries
138 Institutions

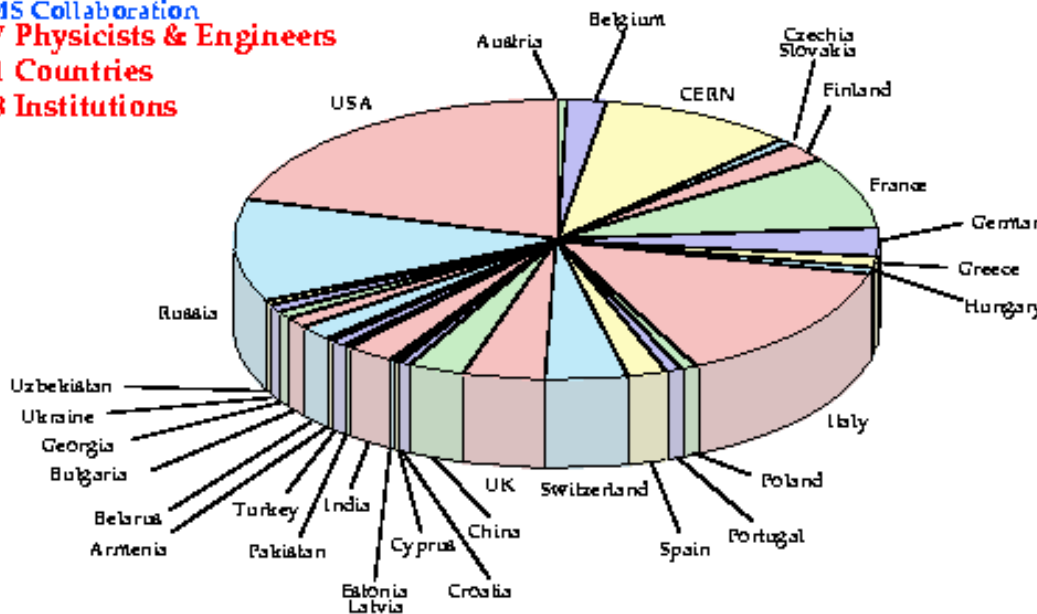

US CMS Demographics

US CMS Collaboration: 365 members from 37 institutions

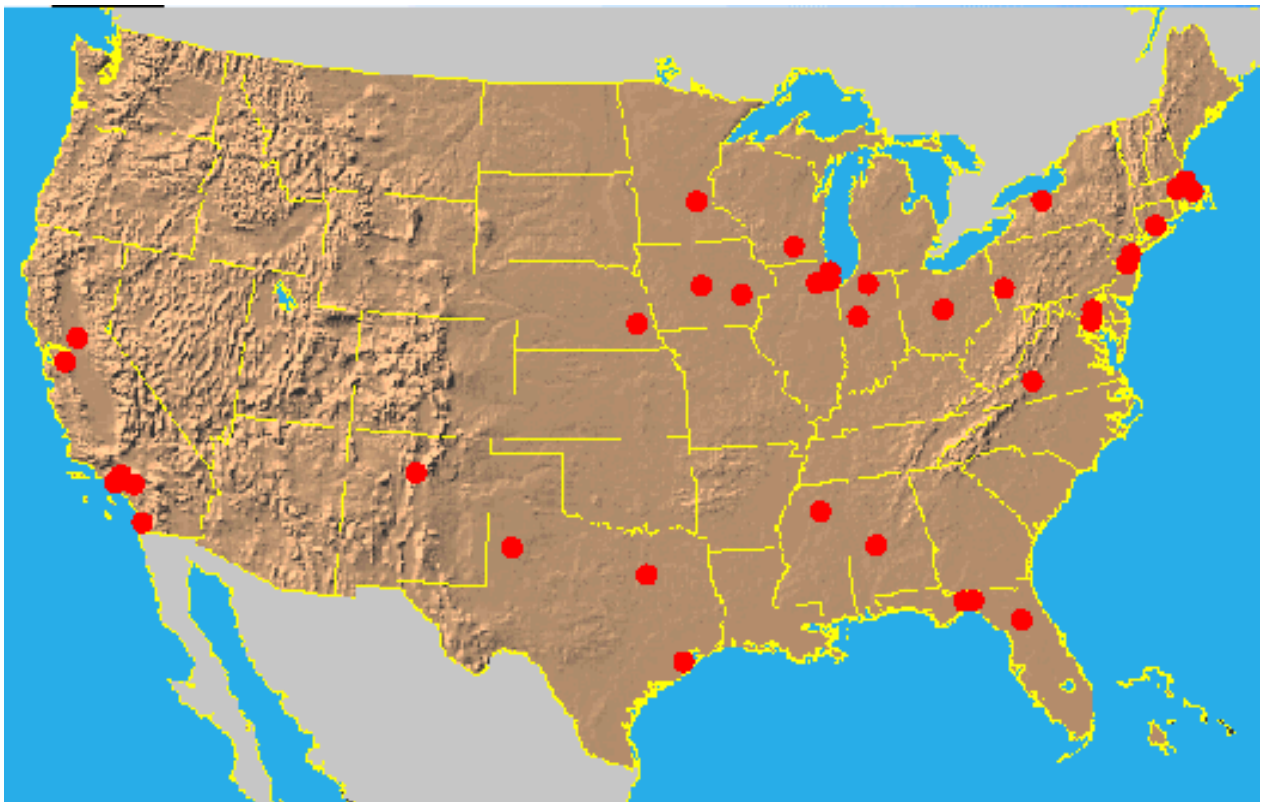

- US CMS Management Responsibilities in CMS

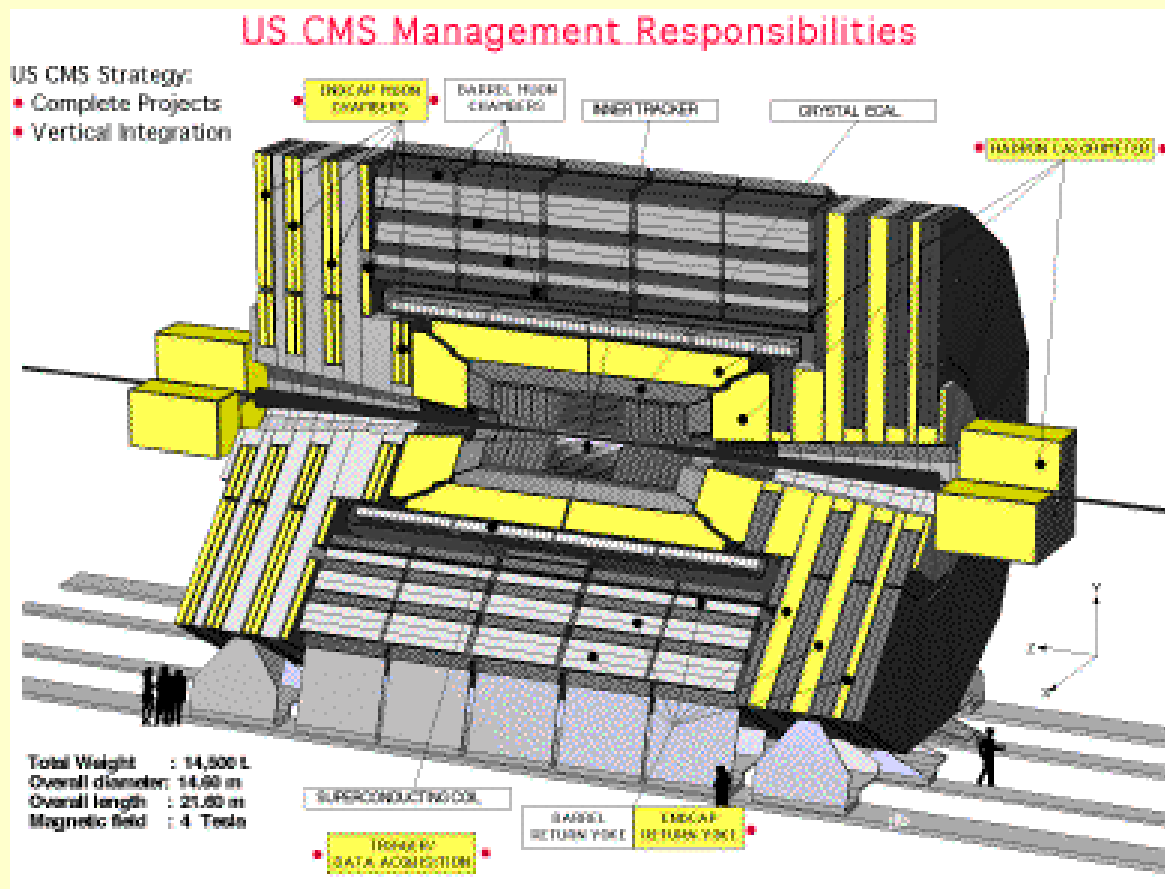

CMS Tracking System

- The Higgs is weakly coupled to ordinary matter. Thus, high interaction rates are required. The CMS pixel Si system has ~ 100 million elements so as to accommodate the resulting track densities.

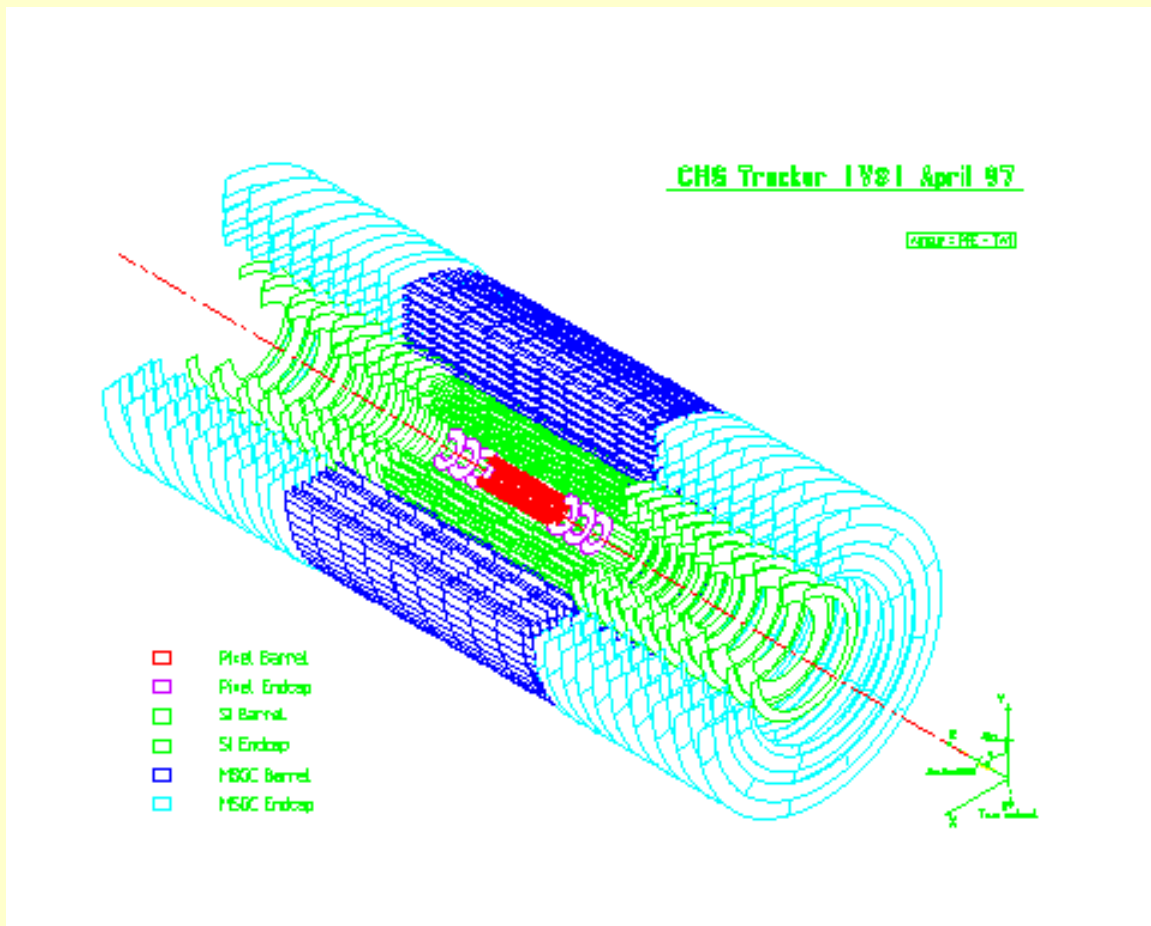

If $M_H > 160$ GeV use $H \rightarrow ZZ \rightarrow 4e$ or 4μ

$H \rightarrow ZZ^* \rightarrow 4$ electrons

CMS full GEANT simulation of

$H(150 \text{ GeV}) \rightarrow ZZ^* \rightarrow 4e$

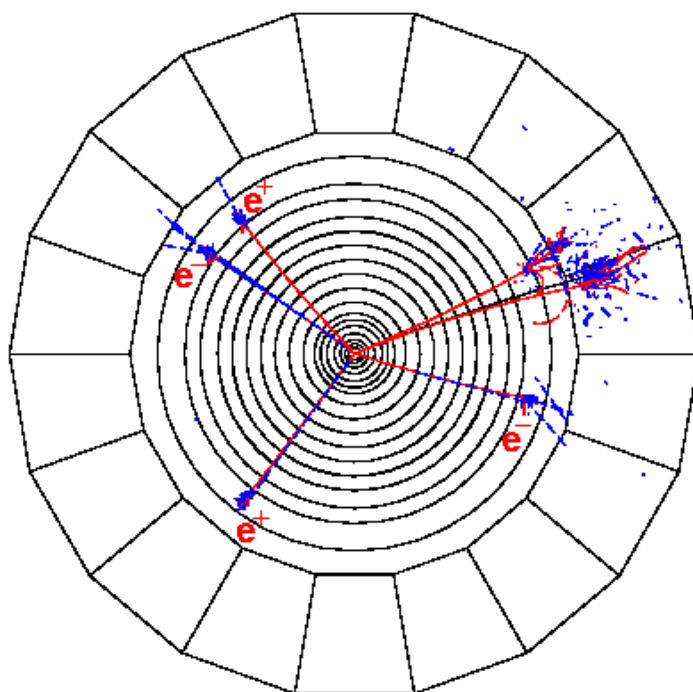
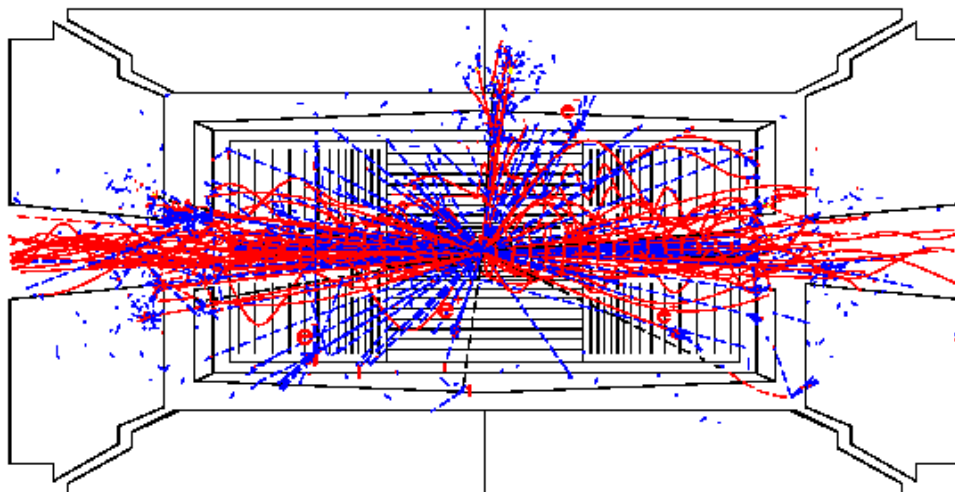

**US CMS
does APD +
FPU +
bit serializer
+ laser
monitoring**

The Hadron Calorimeter

- HCAL detects jets from quarks and gluons. Neutrinos are inferred from missing E_T .

Hadron Calorimeter HCAL

Aim:

- Energy and direction measurement of particle jets, e. g. from $W, Z, q \rightarrow$ jets and/or missing energy \cancel{E}_T .
- Discover new physics, e. g. heavy Higgs, SUSY particles or composites via \cancel{E}_T or $E_{T\cancel{T}}$
- Energy resolution:
$$\sigma_E/E = 65\%/ \sqrt{E} \oplus 5\% \quad [E \text{ in GeV}]$$

Requirements:

- Extend acceptance to the highest possible η value.
- Get best hermeticity (more important than resolution!) of the HCAL (HB, HF, HV).
- Assure adequate sampling depth to avoid leakage.

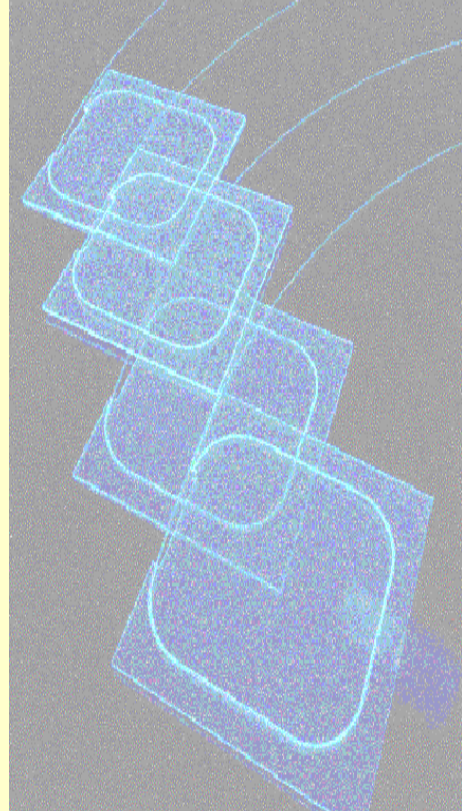
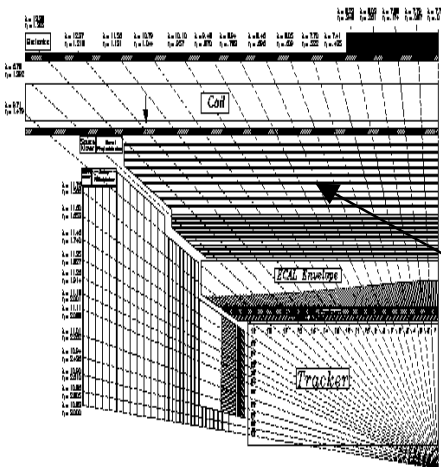

US CMS does all HB and all HCAL transducers and electronics

The CMS Muon System

CMS

Compact Muon Solenoid

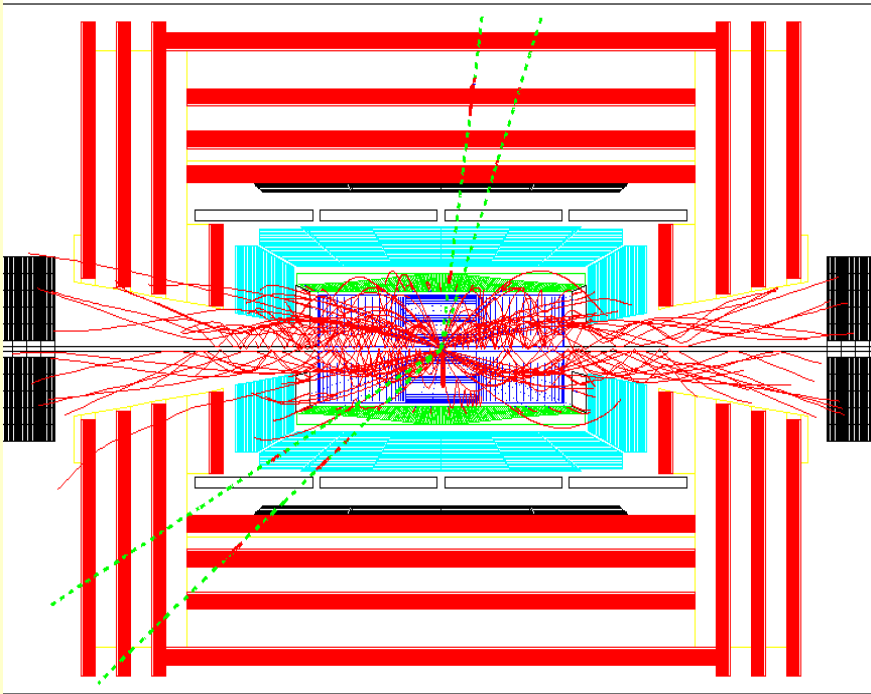

N. Neumeister & N. Sinanis

- The Higgs decay into ZZ to 4μ is preferred for Higgs masses > 160 GeV. Coverage to $|\eta| < 2.5$ is required ($\theta > 6$ degrees)

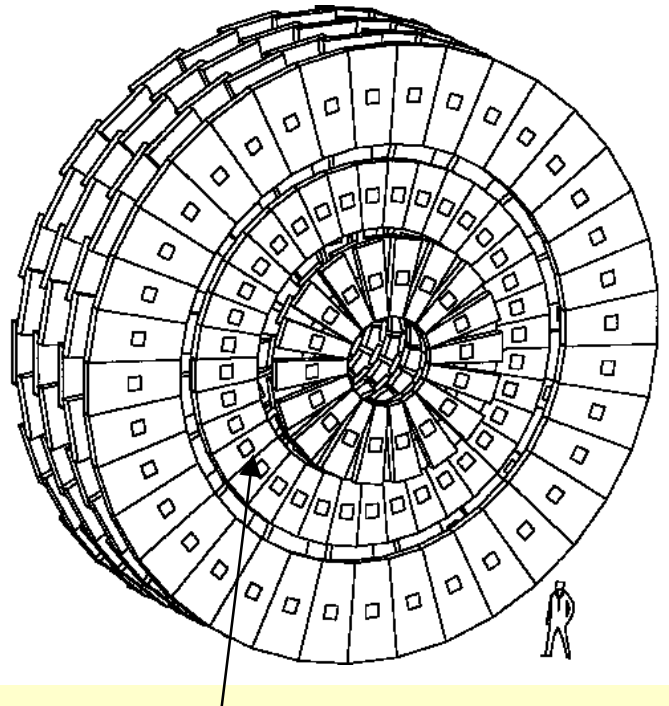

US CMS - ALL ME CSC

CMS Trigger and DAQ System

1 GHz
interactions

40 MHz
crossing rate

< 100 kHz L1
rate

<10 kHz “L2”
rate

< 100 Hz L3
rate to

storage
medium

CMS Trigger and data acquisition computing and communications subsystems

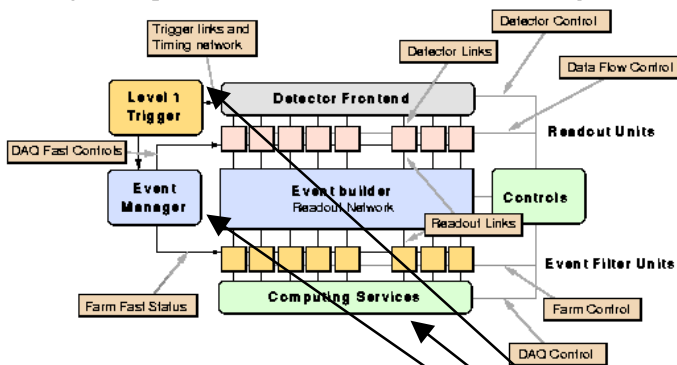

CMS data acquisition main parameters	
Average event size	= 1 MByte
Level-1 Maximum trigger rate	100 kHz
No. of Readout units (200-5000 B yte/event)	1000
Event builder (1000-1000 switch) bandwidth	= 500 Gbit/s
Event filter computing power	= 5·10 ⁴ MIPS
Data production	= TByte/day
No. of readout crates	= 300
No. of electronics boards	= 10000

US CMS - L1
Calorimeter
Triggers and
L1 ME
Triggers and
L2 Event
Manager and
Filter Unit

CMS in the Collision Hall

