



KLINGER
EDUCATIONAL
PRODUCTS CORP.

112-19 14TH ROAD
COLLEGE POINT, NEW YORK 11356
(718) 461-1822

Electron spin resonance; magnetic field dependence of the resonance frequency, determination of the g-factor

The absorption of alternating field energy of a sample in the magnetic field of a pair of Helmholtz coils, on which a high frequency alternating field has been superimposed, is measured with ESR equipment and an oscilloscope in xy-mode. From the relationship between resonance frequency and resonance field strength B of the electromagnet, the g-factor for the spin of the electron g_s is calculated.

A paramagnetic electron spin system - a sample of DIPHENYL-PICRYL-HYDRAZYL (DPPH) - in the coil of the high frequency resonance circuit absorbs high frequency energy in a DC field during resonance. This leads to a measurable change in the resonance circuit's impedance.

With this resonance method, we can discover something about the intrinsic angular momentum of the electron (spin); the magnetic torque, the quantized adjustment possibilities of the spin in outer magnetic field and the energy level connected with it. To do this, bridges between energy levels are induced in high frequency alternating current fields, corresponding to two possible stable spin adjustments in the outer magnetic field.

The organic compound Diphenyl-picryl-hydrazyl (DPPH) is a radical, in which an unpaired electron appears on one of the nitrogen atoms (see Fig. 1).

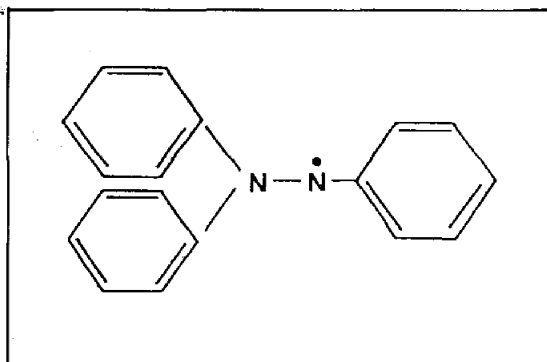

Fig. 1: DPPH

The electrons of a DPPH sample, which do not possess any orbital angular momentum ($l = 0$), are well suited for electron spin resonance experiments.

The sample is placed into a magnetic DC field, which is superimposed by a high frequency magnetic AC field (in the coil of a resonance circuit).

During resonance (the energy of the irradiated photons is equal to the energy difference between two possible stable spin positions; transitions are induced) high frequency energy is absorbed, which is reflected in an alteration of the resonance circuit's impedance.

During electron spin resonance measurement, due to experimental reasons, the frequency of the irradiated microwaves is not adapted, but the strength of the outer magnetic field is varied.

Through modulation of the magnetic DC field, a change in resistance during resonance can periodically be brought about and therefore can be displayed on the oscilloscope.

Vertical deflection plates: voltage proportional to the amplitude of the high frequency field.

Horizontal deflection plates: voltage proportional to the field of the Helmholtz coils.

The resonance frequency f is a function of the resonance field strength B . The dependence is determined experimentally, is then compared with the theoretical result derived below and is then evaluated.

Electron spin resonance formula

A magnetic moment is linked with electron spin. It can be clearly understood by considering the electron as a rotating electric charge and by virtue of the fact that a circular current possesses a magnetic moment. Because of the negative charge of the electron, the magnetic moment acts in the opposite direction to the spin. This clear notion of a rotating electron cannot be taken too literally, because no quantitatively correct results can be derived from it. In particular it does not follow that the electron spin has only half numbers.

The relationship between the electron spin \vec{s} and the magnetic moment $\vec{\mu}_s$ of the electron is expressed in the form

$$\vec{\mu}_s = \frac{g_s \mu_B}{\hbar} \vec{s}$$

μ_B is Bohr's magneton, depicting the structural unit for atomic magnetic moment; and \hbar (read 'h-cross'; $\hbar = h/2\pi$) Planck's action quantum

which in a similar way is the structural unit for atomic angular momentum. The constant g_s is a

value characteristic for the electron, which is designated as the g-factor for the spin of the electron.

It shows the ratio of the values of the magnetic moment to that of the angular momentum in the corresponding atomic units:

$$g_s = \frac{\mu_s}{s} \frac{\mu_B}{\hbar}$$

If the corresponding ratio of magnetic moment and orbital angular momentum is formed, then the experimentally correct value $g=1$ is obtained and for Bohr's magneton one finds $\mu_B = e \cdot \hbar / (2m_0 \cdot c)$; m_0 is the calculation $\mu_B = e \cdot \hbar / (2m_0 \cdot c)$; m_0 is the resting mass of the electron. The g-factor for the spin of an electron cannot be understood with classical physics (see note at end). It can only be understood by means of relativistic quantum mechanics. It has a value of $g_s = 2$ with a

correction factor of 0.1%, which is in agreement with the experiment.

To derive the resonance formula, the results of quantum mechanics are used, with which the orbital angular momentum \vec{l} can be calculated with the formula $\vec{l} = \sqrt{l(l+1)} \cdot \hbar$. l is the angular momentum quantum number. Also, the observable components of the angular momentum are quantized in one privileged direction according to the

formula $l_z = m \cdot \hbar$. m is the magnetic quantum number. The z-direction is defined here by the magnetic field. For the orbital angular momentum with an orbital quantum number l , m must have integral values, $m = 0, +1, +2 \dots +l$. In total, an odd number of $2l + 1$ values and the same number of energy levels are obtained (Z-direction corresponds to the direction of the outer field).

The angular momentum vector \vec{s} follows the same rules as those of the orbital angular momentum.

$$s = \sqrt{s(s+1)} \cdot \hbar$$

$$s_z = m_s \cdot \hbar; \quad m_s = -s, \dots, +s$$

When splitting up the S-basic state ($l = 0$), into two components (even number), we can conclude that the electron has a spin. On the other hand, the spin quantum number must have the value $s = \frac{1}{2}$, so that for all possible values of the magnetic spin quantum number m_s :

$$2 \cdot s + 1 = 2.$$

The magnetic spin quantum number can only take on the value $m_s = +\frac{1}{2}$, this being able to explain the splitting into two levels.

With only two spin sets possible, the magnetic moment of the electron which is coupled with the intrinsic angular momentum has also only two setting possibilities. From

$$\vec{\mu} = -g_s \frac{\mu_B}{\hbar} \vec{s} \text{ and } s_z = \pm \hbar/2$$

it follows that the z-component of the magnetic moment is

$$\mu_z = \pm \frac{1}{2} g_s \mu_B.$$

The potential energy E_m of a magnetic moment $\vec{\mu}$, which is in a magnetic field with the force flux density \vec{B} , is:

$$E_m = \vec{\mu} \cdot \vec{B} = \mu_z B.$$

Accordingly, the energy E_0 , which has an electron without a magnetic field, divided up into the two following levels (compare Fig. 2):

$$E_m = E_0 \pm \frac{1}{2} g_s \mu_B B.$$

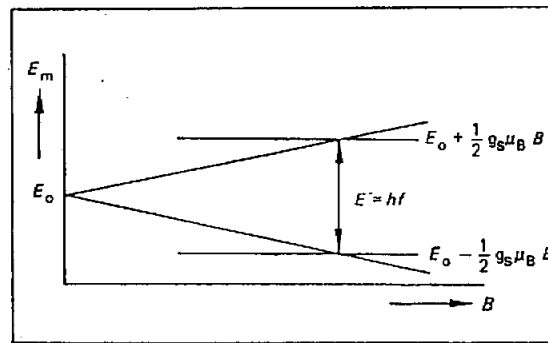

Fig. 2: Splitting up of an energy level in a magnetic field (total impulse $j = s + l = s$) with resonance conditions.

Resonance absorption takes place when the energy of the irradiation photon $E = hf$ is equal to the magnetic splitting up of energy. Here f is the frequency of the beam. As the resonance formula we obtain

$$hf = g_s \mu_B B$$

In general, we must take into consideration the fact that the total angular momentum J is the sum of the orbital angular momentum and the spin.

Apparatus:

1 ESR-basic unit (sample head)	514 55
1 Pair of Helmholtz coils	555 06
3 Saddle bases	300 11
1 Oscilloscope, two-channel	e.g. 575 20
2 Cable, screened, BNC, 4 mm socket	575 24

For power supply:

1 ESR-control unit	514 57
and	
1 Measuring instrument D, measuring range	
3 A, e.g. E measuring instrument D	531 88
3 Connecting leads, 50 cm	501 28
2 Connecting leads, 25 cm	501 23

Setting up:

Connect the Helmholtz coils in parallel, choose a distance for the coils equal to the coil radius r ($r = 6.8 \text{ cm}$).

Important!
Below the current in each coil will be designated I . Because of the parallel connection of both coils, the ammeter displays $2 I$.

Oscilloscope setting
HOR, EXT.

Y_1 : AC; $0,5 \frac{V}{cm}$

X : AC; $2 \frac{V}{cm}$

Point of origin: The middle of the uppermost screen line.

Carrying out the experiment:

- Choose one of the following plug-in coils corresponding to the frequency range of the high frequency alternating current field:

Plug-in coil (E) (f approx. 13 - 30 MHz),
Plug-in coil (F) (f approx. 30 - 75 MHz),
Plug-in coil (G) (f approx. 75 - 130 MHz)

Insert the DPPH-sample.

- If the amplitude of the AC field superimposed with the magnetic DC field is too small, slowly increase the magnetic DC field until impulses can be seen on the screen.

Note:

In general two resonance impulses can be seen. This is because the magnetic AC field goes through the resonance position twice per phase and because there is a phase offset between the voltages shown on the oscilloscope (verify with a two channel oscilloscope: instead of X-input (HOR.EXT.):

Y_{II} -input, TIMEBASE $1 \frac{ms}{cm}$).

- Coincide resonance impulses with the phase shifter and by varying the direct current field, set it symmetrically to the center of the screen ($x = 0$) (example: oscillogram Figure 4).

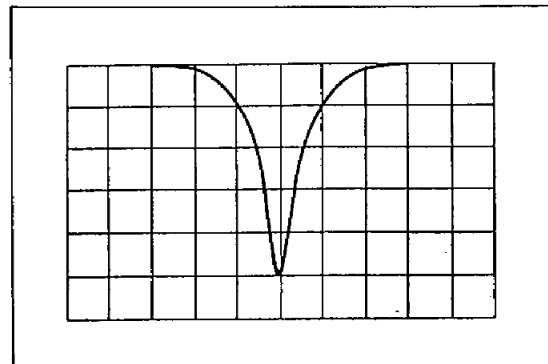

Fig. 4: Oscillogram

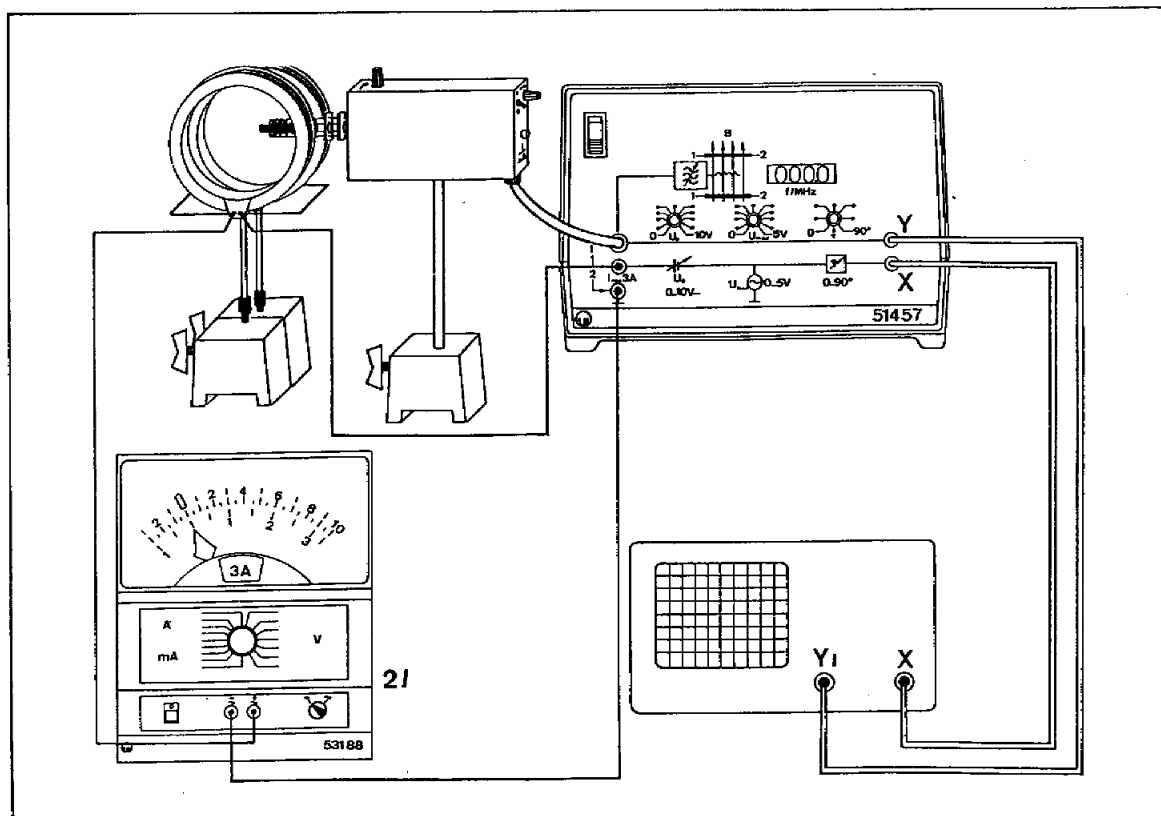

Fig. 3: Experiment setup

- Increase the frequency f of the HF oscillator, so that the resonance line displaces itself to the right on the oscilloscope screen, because resonance only occurs when there is a large magnetic force flux density B .
- By increasing the magnetic direct current field, reset the resonance line back to its original position (middle of the screen) (symmetrical to $X = 0$).
- Measure the frequency f and the direct current amplitude I which is proportional to B . For an exact measurement of I , choose a low ESR signal by decreasing the modulation amplitude of the outer field, and adjust the remaining ESR signal so that it is symmetrical to the middle of the screen ($x = 0$) with the direct current field (see Fig. 5).
- Determine the pair of values f and I according to the methods described (see diagram Fig. 6).

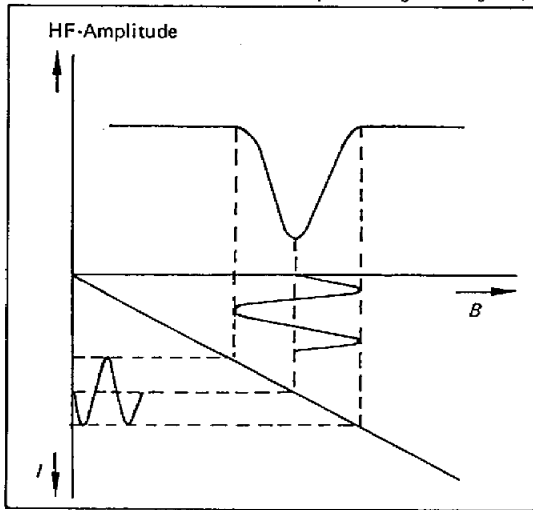

Fig. 5: In the case of a symmetrical resonance impulse its maximum marks the amplitude of the magnetic DC-field with the force flux density B proportional to I .

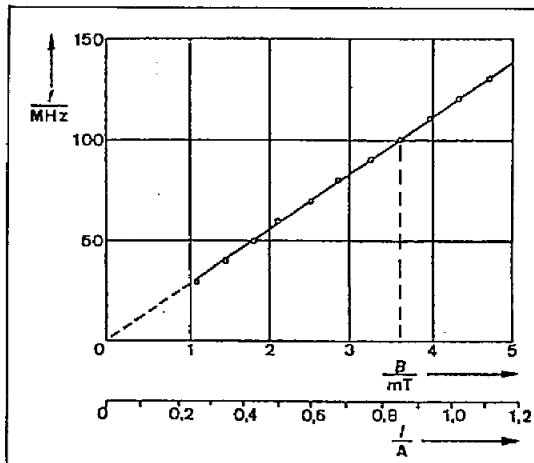

Fig. 6: Resonance frequency f as a function of the magnetic resonance field strength B , proportional to the current measured on the Helmholtz coils.

Deducing B by measuring I:

If the amount of the current in the coil I is known, then the force flux density B of the almost homogenous magnetic field in the pair of Helmholtz coils (distance between the coils = coil radius) can be calculated with Biot-Savart's law.

$$B = \mu_0 \left(\frac{4}{5}\right)^2 \cdot \frac{n}{r} \cdot I$$

n = Number of turns in the coil
 r = Coil radius
 I = Current in each coil

With the magnetic field constant

$$\mu_0 = 1,2566 \cdot 10^{-6} \frac{Vs}{Am}$$

$$n = 320 \text{ und}$$

$$r = 6,8 \text{ cm}$$

$$\text{we get } \frac{B}{mT} = 4,23 \frac{I}{A}$$

Recalibrate the I -abscissa in Fig. 6 according to this relationship.

Measuring example:

The slope of the line is taken from diagram Fig. 6

$$\frac{f}{B} = \frac{100 \text{ MHz}}{3,57 \text{ mT}}$$

Evaluation and result:

The resonance frequency is proportional to the magnetic resonance force flux density B .

From the resonance condition

$$h \cdot f = g_s \cdot \mu_B \cdot B$$

$$\text{it follows that } \frac{f}{B} = \frac{g_s \cdot \mu_B}{h}$$

$$h = 6,625 \cdot 10^{-34} \text{ Js}^2 \text{ (Planck's action quantum)}$$

$$\mu_B = 9,273 \cdot 10^{-24} \text{ Am}^2 \text{ (Bohr's magneton).}$$

The g -factor can be calculated with the help of the experimentally determined slope $\frac{f}{B}$:

$$g_s = \frac{h \cdot f}{\mu_B \cdot B} = \frac{6,625 \cdot 10^{-34} \text{ Js}^2 \cdot 100 \text{ MHz}}{9,273 \cdot 10^{-24} \text{ Am}^2 \cdot 3,57 \text{ mT}} = 2,0$$

The g -factor ($g_s = \frac{h \cdot f}{\mu_B \cdot B}$) which was calculated

with the help of the proportionality constant $\frac{f}{B}$, has the value 2.0.

Note:

The g-factor $g_s = 2$ cannot be understood in classical physics.

$g_s = 2$ means that the spin generates at twice as large a magnetic moment as a classical rotating charge with the angular momentum $1/2 h$.

Literature on electron spin resonance

- (1) Elektronenspin-Resonanz
F. Schneider and M. Plato
Thiemig-Taschenbücher, Band 40
Verlag Karl Thiemig KG, München
- (2) Paramagnetic resonance in solids
W. Low
Academic Press 1960, New York and London
- (3) Principles of Magnetic Resonance
C. P. Slichter
Harper and Row 1963
- (4) Paramagnetic Resonance
G.E. Pake
W. A. Benjamin 1962, New York

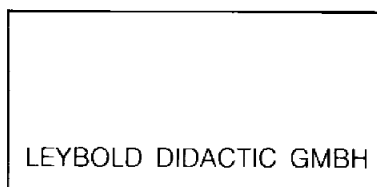
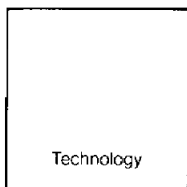
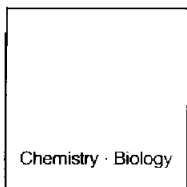
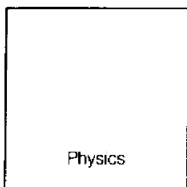

5/89 -Kr-Brs-

Instruction Sheet

514 55/56/57



KLINGER EDUCATIONAL PRODUCTS CORP.

112-19 14TH ROAD COLLEGE POINT, NEW YORK 11356 (718) 461-1822

ESR Basic Unit
ESR Adapter
ESR Control Unit

The ESR basic unit is used in experiments on electron spin resonance, the ESR control unit provides all the required voltages and also digitally indicates the frequency of the oscillatory circuit

The ESR adapter is used in those cases where other power supply units and frequency indicators are used instead of the ESR control unit.

Measuring Principle:

A paramagnetic electron spin system - probe consisting of DIPHENYL-PICRYL-HYDRAZYL (DPPH) - placed between the coils of an r-f oscillatory circuit and applying a constant field, will absorb r-f energy thus measurably changing the impedance of the oscillatory circuit. The impedance change of the constant magnetic field as produced by the modulation can be displayed on an oscilloscope.

Examples of experiments:

- Verification of electron spin resonance
• Magnetic field as a function of resonant frequency (linearity of Zeeman interaction)
• Measurement of the gyromagnetic ratio and factor of g
• ESR line width
• Signal amplitude as a function of resonant frequency

A monograph describing experiments on electron spin resonance is in preparation.

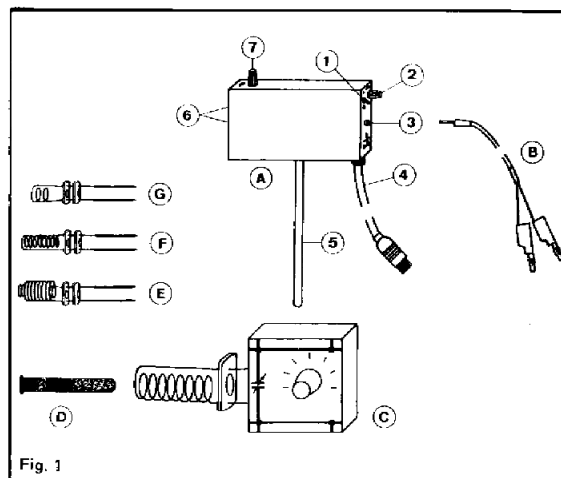

Fig. 1

Control elements:

- 1 On/off switch
2 Potentiometer for r-f amplitude adjustment
3 Socket for measuring cable B
4 Multi-core lead for supply and signal voltages
5 Stand rod
6 Sockets for connecting the r-f plug-in coils
7 Variable capacitor for frequency adjustment

Technical Data:

Supply voltage and current: ±12 V/175 mA
Frequency ranges: with plug-in coil G: 13 to 30 MHz approx. with plug-in coil F: 30 to 75 MHz approx. with plug-in coil E: 75 to 130 MHz approx.
Voltage across the r-f coil: 6 Vpp approx. at 13 MHz amplitude adjusted to maximum
ESR signal: 1 to 6 V approx. (depending on frequency)
Frequency divider: 1000:1
Frequency output for digital counter: TTL
D. C. current (at output 4): 100 µA approx.
Test substance: Diphenyl-Picryl-Hydrazyl (DPPH)
Frequency range of the passive resonant circuit C: 10 to 50 MHz
Dimensions of the probe holder: 130 mm x 70 mm x 40 mm
Length of stand rod: 185 mm
Weight: 0.7 kg approx.

1 Safety

- The ESR control unit can be converted for mains voltages other than 220 V a. c. (see Section 4.2).
□ Output 4 of the ESR control unit (magnet supply)

2 Parts, Description, Technical Data

2.1 514 55 ESR basic unit

The basic unit consists of the following parts:

- A ESR probe holder with frequency divider 1000:1 and signal amplifier
B Measuring lead to use the apparatus as a resonance meter
C Electric resonant circuit, passive (for investigating the relationship between resonant frequency and magnetic field)
D DPPH probe
E, F, G Plug-in coils for different frequency ranges

2.2 514 56 ESR adapter

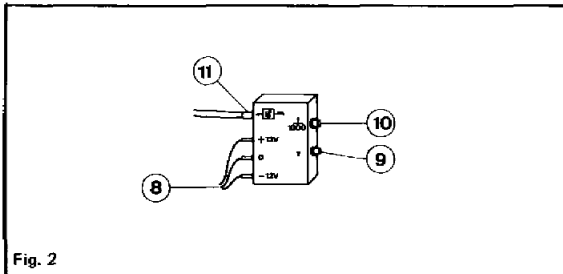

Fig. 2

Control elements:

- ⑧ Supply voltage connection
- ⑨ Signal output Y
- ⑩ Frequency output
- ⑪ Connection for the ESR basic unit (probe holder)

Technical Data:

Signal output Y:	BNC socket
Frequency output $\frac{f}{1000}$:	BNC socket
Supply voltage input +12 V, 0, -12 V:	4-mm sockets
Socket for ESR basic unit:	for 5-pin connector
Dimensions:	95 mm x 75 mm x 25 mm
Weight:	0.2 kg

Technical Data:

Mains connection:	110/130/220/240 V a. c., 50/60 Hz
Primary fuse:	0.8 A (slow blow) for 220 V and 240 V (Spare Part No. 69 814) 1.6 A (slow blow) for 110 V and 130 V (Spare Part No. 69 817)
Magnetic field supply:	0 to 10 V d. c. 0 to 5 V a. c. max. current 3 A (no overload protection!)
Phase shifter:	0 to 90°
Digital frequency indication:	4 digits
Signal output:	BNC socket
Modulation output:	BNC socket
Magnet supply output:	pair of 4-mm sockets
Dimensions:	30 cm x 21 cm x 23 cm
Weight:	6.2 kg approx.

2.3 514 57 ESR control unit

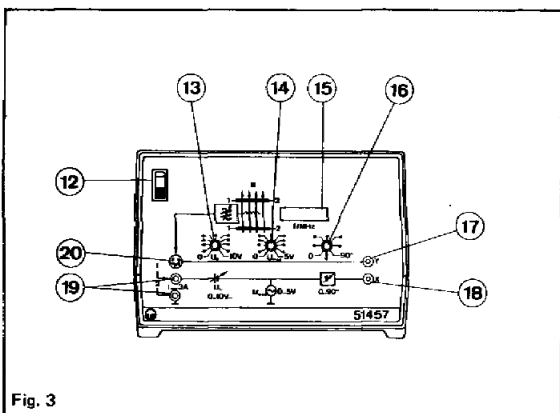

Fig. 3

Control elements:

- ⑫ On/off switch
- ⑬ D. C. voltage adjusting potentiometer
- ⑭ Modulation voltage adjusting potentiometer
- ⑮ Digital frequency indication
- ⑯ Phase shifter
- ⑰ Signal output
- ⑱ Modulation output
- ⑲ Output magnet supply
- ⑳ Socket for connection to the ESR basic unit (probe holder)

3 Experiment Assemblies, Operation

3.1 Assembly for demonstrating the operating principle of the ESR basic unit (514 55)

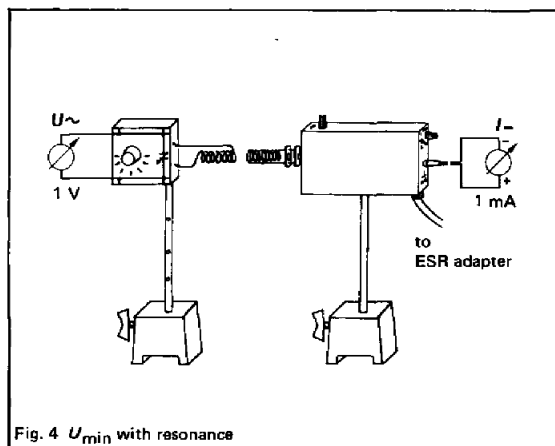
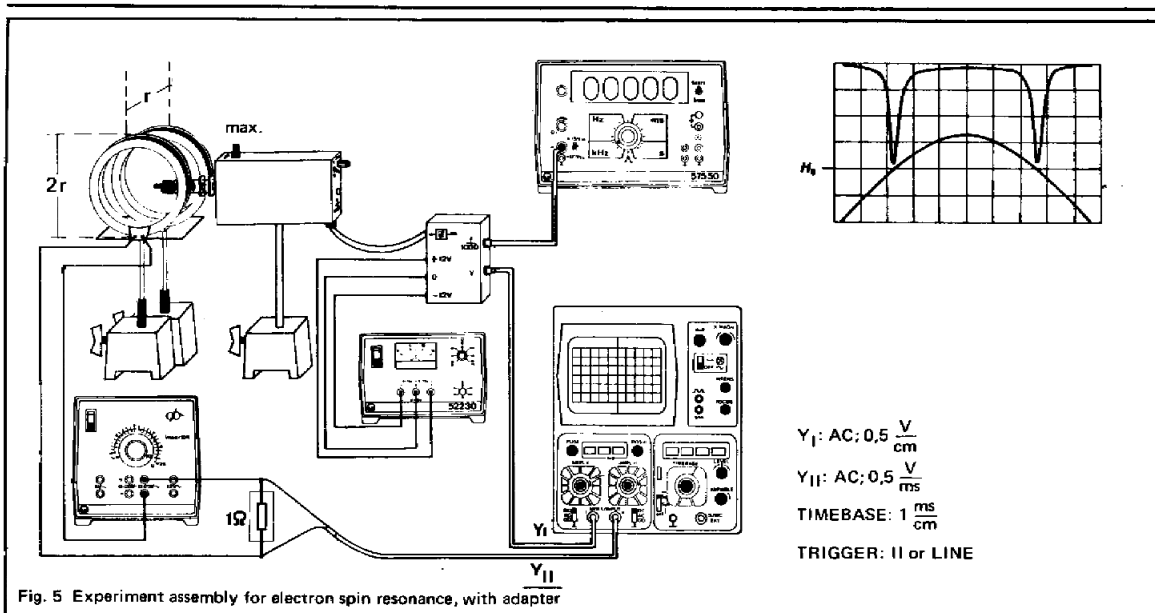

Fig. 4 U_{\min} with resonance

Equipment:

Equipment:	Cat. No.
1 ESR basic unit (probe holder)	514 55
1 Perforated stand rod	590 13
2 Saddle bases	300 11
1 D. C. power supply, stabilized	522 30
1 ESR adapter	514 56
or instead of (522 20) and (514 56):	
1 ESR control unit	514 57
1 Voltmeter, range 1 V a. c.	
1 Ammeter, range: 1 mA d. c.	
e. g. E measuring instruments D.	531 88



3.2 Assembly for demonstrating electron spin resonance

Equipment:

1 ESR basic unit (probe holder)	Cat. No.	514 55
1 Pair of Helmholtz coils		555 06
3 Saddle bases		300 11
1 Two-channel oscilloscope, e. g.		575 20

Power supply options:

a) 1 ESR control unit	514 57
and	
1 Ammeter, range: 3 A, e. g.	
E measuring instrument D	531 88

or	
b) 1 ESR adapter	514 56
1 Measuring resistor, 1Ω	536 10
1 D. C. power supply unit, regulated	522 30
1 Low-voltage transformer SE	522 20
or	
Low-voltage transformer S	591 09
1 Digital counter	575 50
or	
Counter P	575 45
and stop-clock, e. g.	313 05

